



HYDRO WASH X7

User Instructions

©2022 ADJ Products, LLC all rights reserved. Information, specifications, diagrams, images, and instructions herein are subject to change without notice. ADJ Products, LLC logo and identifying product names and numbers herein are trademarks of ADJ Products, LLC. Copyright protection claimed includes all forms and matters of copyrightable materials and information now allowed by statutory or judicial law or hereinafter granted. Product names used in this document may be trademarks or registered trademarks of their respective companies and are hereby acknowledged. All non-ADJ Products, LLC brands and product names are trademarks or registered trademarks of their respective companies.

ADJ Products, LLC and all affiliated companies hereby disclaim any and all liabilities for property, equipment, building, and electrical damages, injuries to any persons, and direct or indirect economic loss associated with the use or reliance of any information contained within this document, and/or as a result of the improper, unsafe, insufficient and negligent assembly, installation, rigging, and operation of this product.

ADJ PRODUCTS LLC World Headquarters

6122 S. Eastern Ave. | Los Angeles, CA 90040 USA

Tel: 800-322-6337 | Fax: 323-582-2941 | www.adj.com | lsupport@adj.com

ADJ Supply Europe B.V.

Junostraat 2 | 6468 EW Kerkrade | Netherlands

Tel: +31 45 546 85 00 | Fax: +31 45 546 85 99 | www.americandj.eu | service@americandj.eu

Europe Energy Saving Notice

Energy Saving Matters (EuP 2009/125/EC)

Saving electric energy is a key to help protecting the environment. Please turn off all electrical products when they are not in use. To avoid power consumption in idle mode, disconnect all electrical equipment from power when not in use. Thank you!

DOCUMENT VERSION



Due to additional product features and/or enhancements, an updated version of this document may be available online.

Please check www.adj.com for the latest revision/update of this manual before beginning installation and/or programming.

Date	Document Version	Software Version	DMX Channel Mode	Notes
09/27/19	1	1.0	15 / 17 / 41	Initial Release
10/10/19	1.2	N/C	N/C	Software Update Instructions Added
12/01/19	1.3	1.3	N/C	Updated Display Lock/Unlock Feature
04/22/21	1.5	N/C	N/C	Updated Dimensions
07/20/21	2.0	N/C	N/C	Updated Antenna Range
10/22/21	2.5	N/C	N/C	Modified Channel 41
03/11/22	3.0	2.1	15 / 17 / 22 / 41 / 46	Corrected Color Macro Chart, Updated DMX Traits
05/17/22	3.5	N/C	No Change	Updated Overview, Safety Guidelines, DMX Addressing, System Menu, DMX Traits, Updating Software, and Specifications.
12/13/22	3.6	N/C	N/C	Updated IP65 Notes in Specifications

CONTENTS

General Information	4
Limited Warranty (USA Only)	5
IP Notice	6
Safety Guidelines	7
Maintenance Guidelines	10
Overview	11
Torque Settings & IP Tester	12
Fixture Installation	14
Connections	16
DMX Setup	17
DMX Addressing	19
System Menu	20
WiFly Control	27
DMX Traits	28
Color Macro Chart	33
Target Modes	34
Dimmer Curve Chart	35
Error Codes	36
Updating Software Multiple Unit Power Linking	37
Specifications	38
Dimensions	39
FCC Statement	41

GENERAL INFORMATION

INTRODUCTION

Please read and understand all instructions in this manual carefully and thoroughly before attempting to operate these products. These instructions contain important safety and use information.

UNPACKING

The products in this kit have been thoroughly tested and have been shipped in perfect operating condition. Carefully check the shipping carton for damage that may have occurred during shipping. If the carton appears to be damaged, carefully inspect each unit included for damage and be sure all accessories necessary to operate the units have arrived intact. In the event damage has been found or parts are missing, please contact our customer support team for further instructions. Please do not return this kit to your dealer without first contacting customer support at the number listed below. Please do not discard the shipping carton in the trash. Please recycle whenever possible.

WARRANTY RETURNS

All returned service items whether under warranty or not, must be freight pre-paid and accompany a return authorization (R.A.) number. The R.A. number must be clearly written on the outside of the return package. A brief description of the problem as well as the R.A. number must also be written down on a piece of paper and included in the shipping container. If the unit is under warranty, you must provide a copy of your proof of purchase invoice. Items returned without a R.A. number clearly marked on the outside of the package will be refused and returned at customer's expense. You may obtain a R.A. number by contacting customer support.

LIMITED WARRANTY (USA ONLY)

- A. ADJ Products, LLC hereby warrants, to the original purchaser, ADJ Products, LLC products to be free of manufacturing defects in material and workmanship for a prescribed period from the date of purchase (see specific warranty period on reverse). This warranty shall be valid only if the product is purchased within the United States of America, including possessions and territories. It is the owner's responsibility to establish the date and place of purchase by acceptable evidence, at the time service is sought.
- B. For warranty service, you must obtain a Return Authorization number (RA#) before sending back the product-please contact ADJ Products, LLC Service Department at 800-322-6337. Send the product only to the ADJ Products, LLC factory. All shipping charges must be pre-paid. If the requested repairs or service (including parts replacement) are within the terms of this warranty, ADJ Products, LLC will pay return shipping charges only to a designated point within the United States. If the entire instrument is sent, it must be shipped in its original package. No accessories should be shipped with the product. If any accessories are shipped with the product, ADJ Products, LLC shall have no liability whatsoever for loss of or damage to any such accessories, or for the safe return thereof.
- C. This warranty is void if the serial number has been altered or removed; if the product is modified in any manner which ADJ Products, LLC concludes, after inspection, affects the reliability of the product, if the product has been repaired or service by anyone other than ADJ Products, LLC factory unless prior written authorization was issued to purchaser by ADJ Products, LLC; if the product is damaged because not properly maintained as set forth in the instruction manual.
- D. This is not a service contract, and this warranty does not include maintenance, cleaning or periodic check up. During the period specified above, ADJ Products, LLC will replace defective parts at its expense with new or refurbished parts, and will absorb all expenses for warranty service and repair labor by reason of defects in material or workmanship. The sole responsibility of ADJ Products, LLC under this warranty shall be limited to the repair of the product, or replacement thereof, including parts, at the sole discretion of ADJ Products, LLC. All products covered by this warranty were manufactured after August 15, 2012, and bear identifying marks to that effect.
- E. ADJ Products, LLC reserves the right to make changes in design and/or improvements upon its products without any obligation to include these changes in any products theretofore manufactured.
- F. No warranty, whether expressed or implied, is given or made with respect to any accessory supplied with products described above. Except to the extent prohibited by applicable law, all implied warranties made by ADJ Products, LLC in connection with this product, including warranties of merchantability or fitness, are limited in duration to the warranty period set forth above. And no warranties, whether expressed or implied, including warranties of merchantability or fitness, shall apply to this product after said period has expired. The consumer's and/or Dealer's sole remedy shall be such repair or replacement as is expressly provided above; and under no circumstances shall ADJ Products, LLC be liable for any loss or damage, direct or consequential, arising out of the use of, or inability to use, this product.
- G. This warranty is the only written warranty applicable to ADJ Products, LLC Products and supersedes all prior warranties and written descriptions of warranty terms and conditions heretofore published.

LIMITED WARRANTY PERIODS

- **Non L.E.D. Lighting Products = 1-year (365 days) Limited Warranty** (Such as: Special Effect Lighting, Intelligent Lighting, UV lighting, Strobes, Fog Machines, Bubble Machines, Mirror Balls, Par Cans, Trussing, Lighting Stands etc. excluding LED and lamps)
- **Laser Products = 1 Year (365 Days) Limited Warranty** (excludes laser diodes which have 6 month limited warranty)
- **L.E.D. Products = 2-year (730 days) Limited Warranty** (excluding batteries which have a 180 day limited warranty)
Note: 2 Year Warranty only applies to purchases within the United States.
- **StarTec Series = 1 Year Limited Warranty** (excluding batteries which have a 180 day limited warranty)
- **ADJ DMX Controllers = 2 Year (730 Days) Limited Warranty**

IP NOTICE

IP65 RATED

An IP rated lighting fixture is one, which is commonly installed in outdoor environments and has been designed with an enclosure that effectively protects the ingress (entry) of external foreign objects such as dust and water. The International Protection (IP) rating system is commonly expressed as “IP” (Ingress Protection) followed by two numbers (i.e. IP65) where the numbers define the degree of protection. The first digit (Foreign Bodies Protection) indicates the extent of protection against particles entering the fixture and the second digit (Water Protection) indicates the extent of protection against water entering the fixture. An IP65 rated lighting fixture is one, which has been designed and tested to protect against the ingress of dust (6) and low-pressure water jets from any direction (5).

NOTE: THIS FIXTURE IS INTENDED FOR TEMPORARY OUTDOOR USE ONLY!



MARINE/COASTAL ENVIRONMENT INSTALLATIONS

NOT suitable for marine and/or coastal environment installations. Installing this fixture in a marine and/or coastal environment may cause corrosion and/ or excessive wear to the interior and/or exterior components of the fixture. Damages and/or performance issues resulting from installation in a marine and/or coastal environment will void the manufactures warranty and will NOT be subject to any warranty claims and/or repairs.

SAFETY GUIDELINES

To guarantee a smooth operation, it is important to follow all instructions and guidelines in this manual. ADJ PRODUCTS LLC is not responsible for injury and/or damages resulting from the misuse of these devices due to the disregard of the information printed in this manual. Only qualified and/or certified personnel should perform installation of these devices and only the original rigging parts included with these devices should be used for installation. Any modifications to these devices and/or the included mounting hardware will void the original manufactures warranty and increase the risk of damage and/or personal injury.



PROTECTION CLASS 1 – DEVICES MUST BE PROPERLY GROUNDED



THERE ARE NO USER SERVICEABLE PARTS INSIDE THESE DEVICES. DO NOT ATTEMPT ANY REPAIRS YOURSELF; DOING SO WILL VOID YOUR MANUFACTURES WARRANTY. DAMAGES RESULTING FROM MODIFICATIONS TO THESE DEVICES AND/OR THE DISREGARD OF SAFETY INSTRUCTIONS AND GUIDELINES IN THIS MANUAL VOID THE MANUFACTURES WARRANTY AND ARE NOT SUBJECT TO ANY WARRANTY CLAIMS AND/OR REPAIRS.



**DO NOT PLUG THIS UNIT INTO A DIMMER PACK!
DO NOT REMOVE THE COVER UNDER ANY CONDITIONS!
NEVER OPERATE THIS UNIT WITH THE COVER REMOVED!
UNPLUG POWER DURING LONG PERIODS OF NON-USE
NEVER TOUCH LIGHT DURING OPERATION, AS IT MAY BE HOT!
KEEP FLAMMABLE MATERIALS AWAY FROM THESE DEVICES!
DO NOT EXCEED OPERATING TEMPERATURES OF 167°F (75°C)!**



ENSURE ALL CONNECTIONS AND END CAPS ARE PROPERLY SEALED WITH A DIELECTRIC GREASE (AVAILABLE AT MOST ELECTRICAL SUPPLIERS) TO PREVENT WATER CORROSION AND/OR ELECTRICAL SHORT CIRCUIT.



IF THE FIXTURE IS EXPOSED TO ENVIRONMENTAL TEMPERATURE CHANGES SUCH AS RELOCATION FROM AN OUTDOOR COLD TO AN INDOOR WARM ENVIRONMENT, DO NOT POWER THE FIXTURE ON IMMEDIATELY. INTERNAL CONDENSATION AS A RESULT OF ENVIRONMENTAL TEMPERATURE CHANGE CAN CAUSE INTERNAL FIXTURE DAMAGE. LEAVE THE FIXTURE POWERED OFF UNTIL IT HAS REACHED ROOM TEMPERATURE BEFORE POWERING ON.



NEVER LOOK DIRECTLY INTO THE LIGHT SOURCE! RETINA INJURY RISK - MAY INDUCE BLINDNESS! SENSITIVE PERSONS MAY SUFFER AN EPILEPTIC SHOCK!

SAFETY GUIDELINES

DO NOT position devices close to any FLAMMABLE MATERIALS while operating.

DO NOT attempt installation and/or operation of devices without knowledge how to do so.

DO NOT permit operation by persons who are not qualified to operate these types of devices.

DO NOT shake devices, avoid brute force when installing and/or operating.

DO NOT operate these devices if the main power cord has become frayed, crimped and/or damaged. Replace any damaged power cords with a similar power rating.

DO NOT remove or break-off the ground plug from the device power cords.

DO NOT remove disassemble devices, there are NO user serviceable parts inside.

ALWAYS disconnect devices from main power source before performing any cleaning.

ALWAYS disconnect light from main power before replacing lamp.

ALWAYS be sure to install these devices in an area that will allow proper ventilation.

NEVER remove the ground prong from the power cable.

Power cords should be safely routed and secured so they are not likely pinched.

Disconnect power cords during long periods of non-use.

Only use recommended rigging hardware as described in this guide.

Use the original packaging and materials to transport these devices in for service.

These devices should be serviced by qualified service personnel when:

- The power cords or plugs have become damaged.
- Objects have fallen on and/or liquid has spilled into the devices.
- The devices have been exposed to rain and/or moisture.
- The devices do not operate normally or exhibit a marked change in performance.

SAFETY GUIDELINES

POTENTIAL INTERNAL FIXTURE DAMAGE FROM EXTERNAL SOURCES OF LIGHT BEAMS

External sources of light beams from direct sunlight, lighting moving head fixtures, and lasers, which are focused directly towards the exterior housing and/or penetrate the front lens opening of ADJ lighting fixtures, can cause severe internal damage including burning to optics, dichroic color filters, glass and metal gobos, prisms, animation wheels, frost filters, iris, shutters, motors, belts, wiring, discharge lamps, and LEDs.

This issue is not specific only to ADJ lighting fixtures, it is a common issue with lighting fixtures from all manufacturers. Although there is no true way to fully prevent this issue from happening, the guidelines below can prevent any potential damage from occurring if followed. Contact ADJ Service for more details.

DO NOT EXPOSE THE FIXTURE AND/OR FRONT LENS OPENING TO LIGHT BEAMS FROM DIRECT SUNLIGHT, OTHER LIGHTING MOVING HEAD FIXTURES, AND LASERS WHILE UNPACKING, INSTALLATION, USE, AND EXTENDED IDLE TIMES OUTDOORS. DO NOT FOCUS A LIGHT BEAM FROM ONE LIGHTING FIXTURE DIRECTLY TOWARDS ANOTHER.

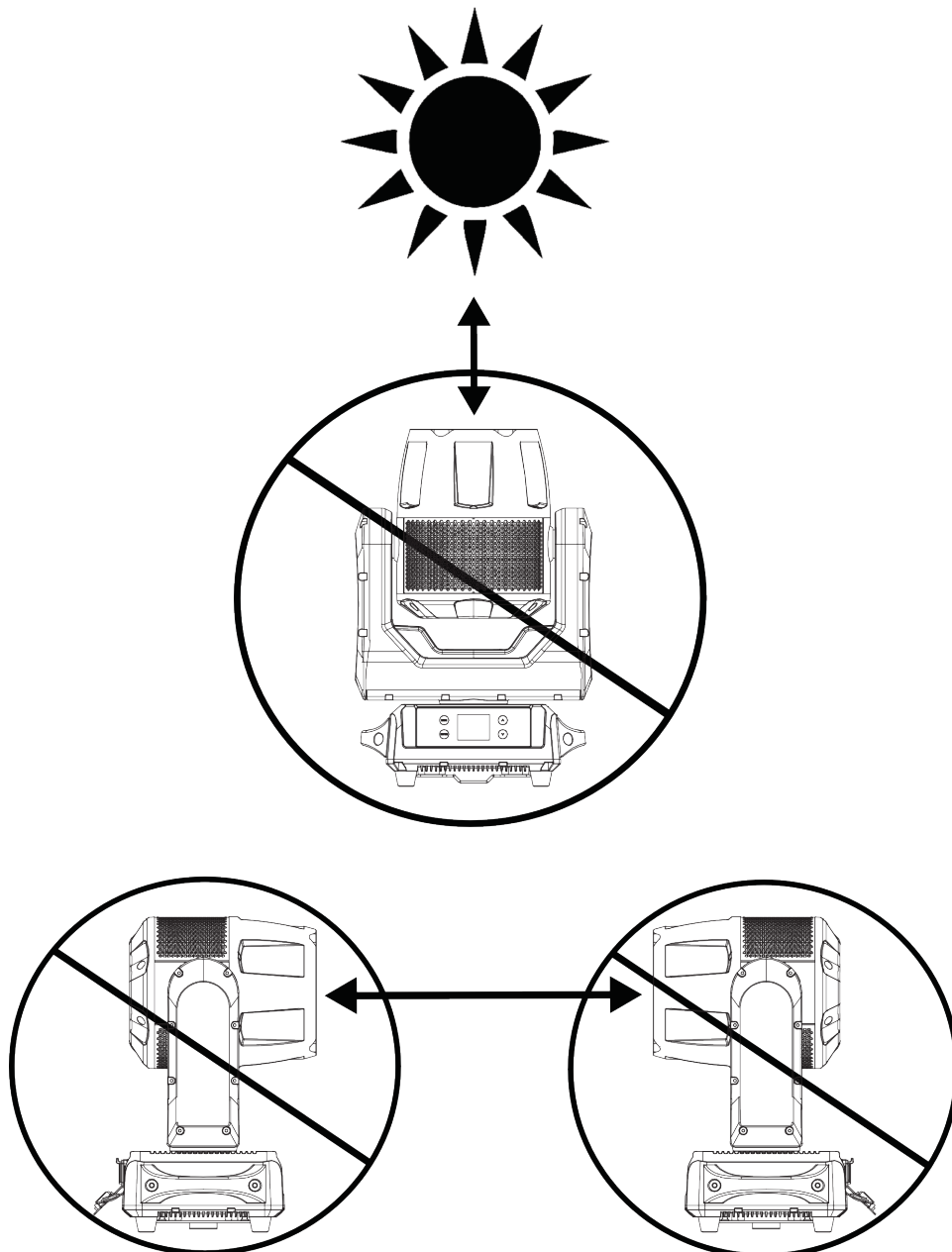

MAINTENANCE GUIDELINES



DISCONNECT POWER BEFORE PERFORMING ANY MAINTENANCE!

CLEANING

Frequent cleaning is recommended to insure proper function, optimized light output, and an extended life. The frequency of cleaning depends on the environment in which the fixture operates: damp, smoky or particularly dirty environments can cause greater accumulation of dirt on the fixture's optics. Clean the external lens surface at least every 20 days with a soft cloth to avoid dirt/debris accumulation.

NEVER use alcohol, solvents, or ammonia-based cleaners.

MAINTENANCE

Regular inspections are recommended to insure proper function and extended life.

There are no user serviceable parts inside this fixture, please refer all other service issues to an authorized Elation service technician. Should you need any spare parts, please order genuine parts from your local Elation dealer.

Please refer to the following points during routine inspections:

- A detailed electric check by an approved electrical engineer every three months, to make sure the circuit contacts are in good condition and prevent overheating.
- Be sure all screws and fasteners are always securely tightened. Loose screws may fall out during normal operation resulting in damage or injury as larger parts could fall.
- Check for any deformations on the housing, color lenses, rigging hardware and rigging points (ceiling, suspension, trussing). Deformations in the housing could allow for dust to enter the fixture. Damaged rigging points or unsecured rigging could cause the fixture to fall and seriously injure a person(s).
- Electric power supply cables must not show any damage, material fatigue or sediments.

NEVER remove the ground prong from the power cable.

OVERVIEW

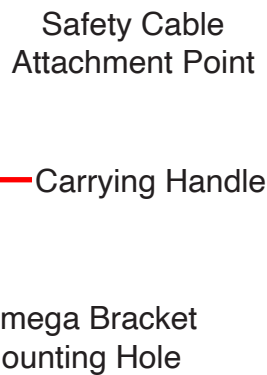
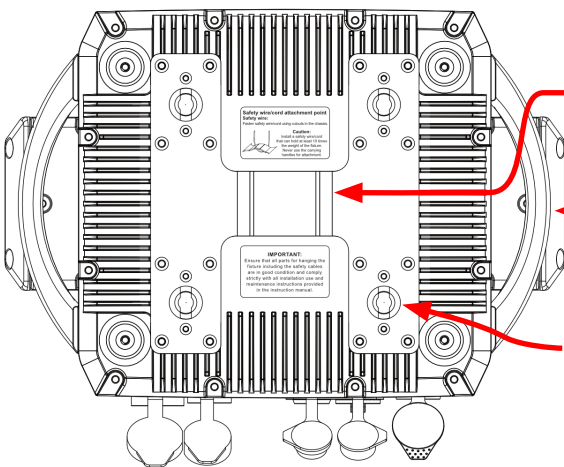
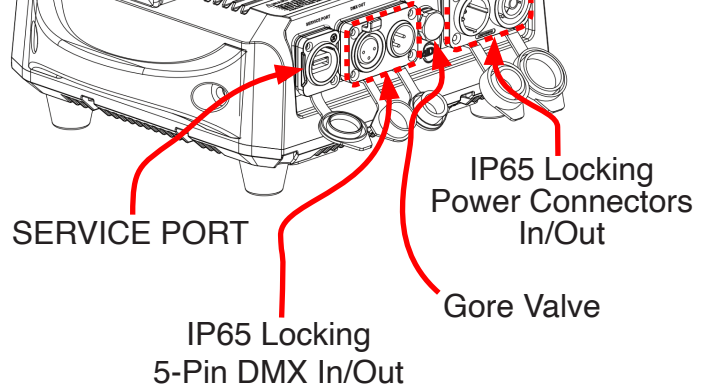
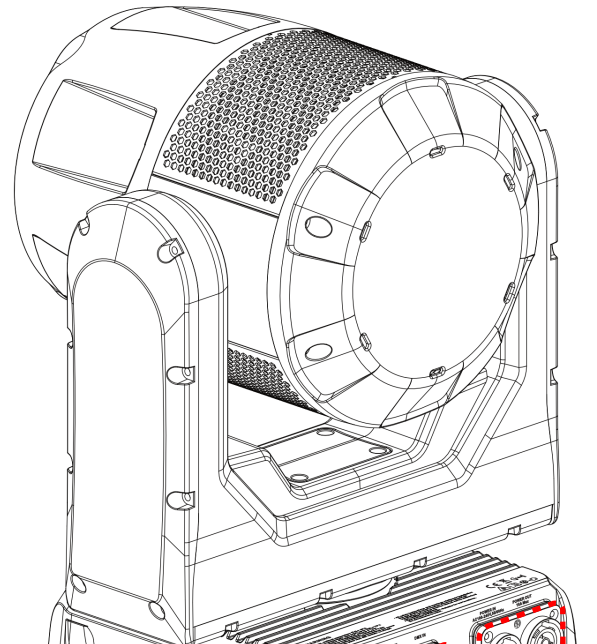
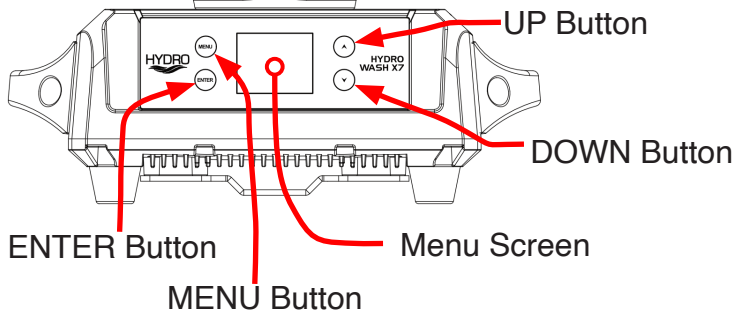
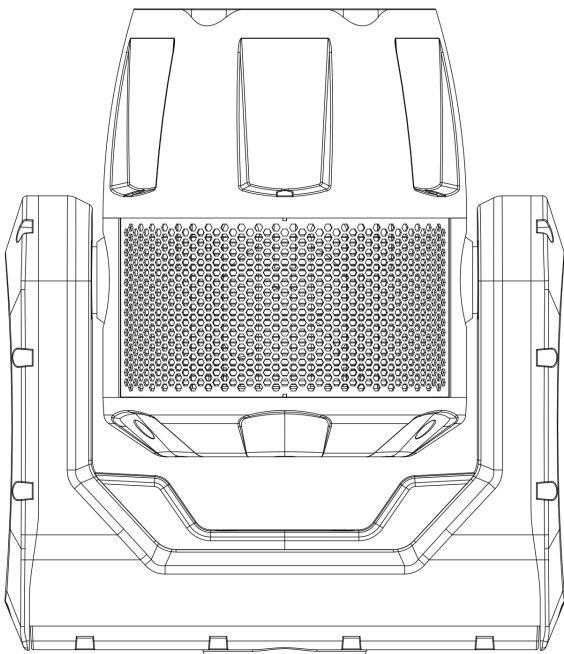

OMEGA BRACKETS INSTALLATION

Insert the Omega Brackets into the matching holes on the bottom of the fixture. Secure the Omega Brackets to the fixture by turning each quick-lock fastener ¼ turn clockwise; making sure the fastener is completely locked.

TORQUE SETTINGS & IP TESTER

TORQUE SETTINGS FOR SCREWS

ALL SCREWS MUST BE TIGHTENED WITH A TORQUE DRIVER. All screws are Allen Head screws. Please see below for screw locations, screw quantity and torque settings. The number listed in the “#” column corresponds to the location on the fixture. See the fixture diagram and numbers on the next page for **SCREW LOCATIONS**.

#	SCREW LOCATIONS	SCREW TORQUE SETTINGS
1	Lens Assembly to Head Casting (6x)	6.5 - 8.7 In-Lb
2	Lamp Cover to Head Casting	6.5 - 8.7 In-Lb
3	Yoke Arm Cover to Yoke Frame (8x Each Side = 16 Total)	6.5 - 8.7 In-Lb
4	Access Cover to Yoke Frame (4x)	Fasten via Manual Screwdriver
5	Handle to Base Casting (2x Each Side = 4 Total)	Fasten via Pneumatic Screwdriver
6	Bottom Cover to Base Casting (12x)	6.7 - 9.6 In-Lb
7	Power & Data Connector to Base Casting (10x)	6.5 - 8.7 In-Lb
8	1/4 Turn Adapter Plate to Bottom Cover (16x)	6.5 - 8.7 In-Lb

TORQUE DRIVERS (Recommended):
UTICA TS-30 (Shown)

ALTERNATIVE DRIVERS:
Proto J6107A
Wiha 28887



CAUTION! DO NOT OVER TORQUE SCREWS AS THIS CAN CAUSE LEAKAGE ISSUES! TO CONFIRM THE IP65 INTEGRITY AFTER A LAMP REPLACEMENT, TEST THE FIXTURE USING THE ELATION IP TESTER. CONTACT ELATION SERVICE FOR MORE DETAILS.



TORQUE SETTINGS & IP TESTER

TORQUE SCREW LOCATIONS

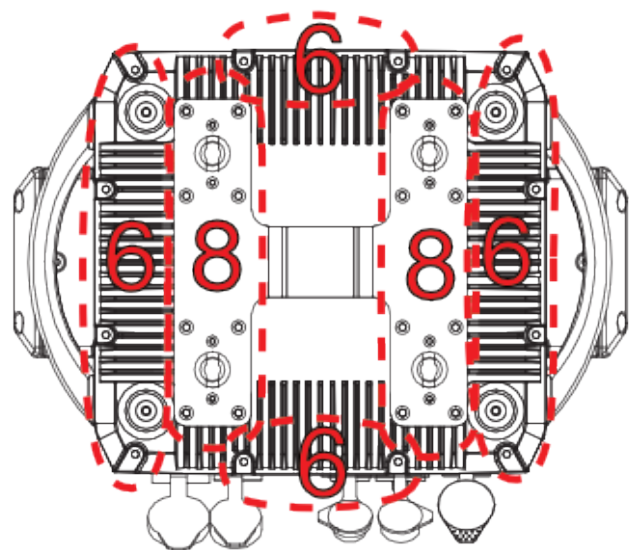
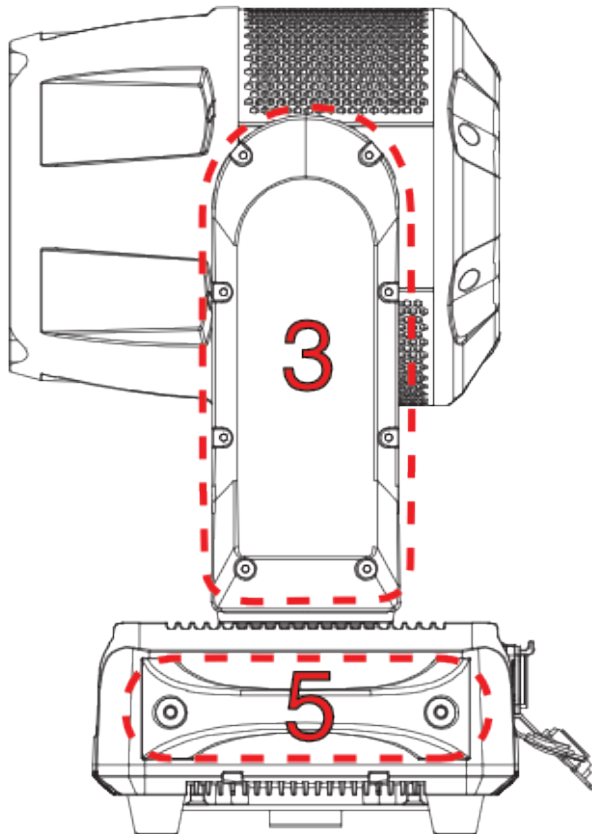
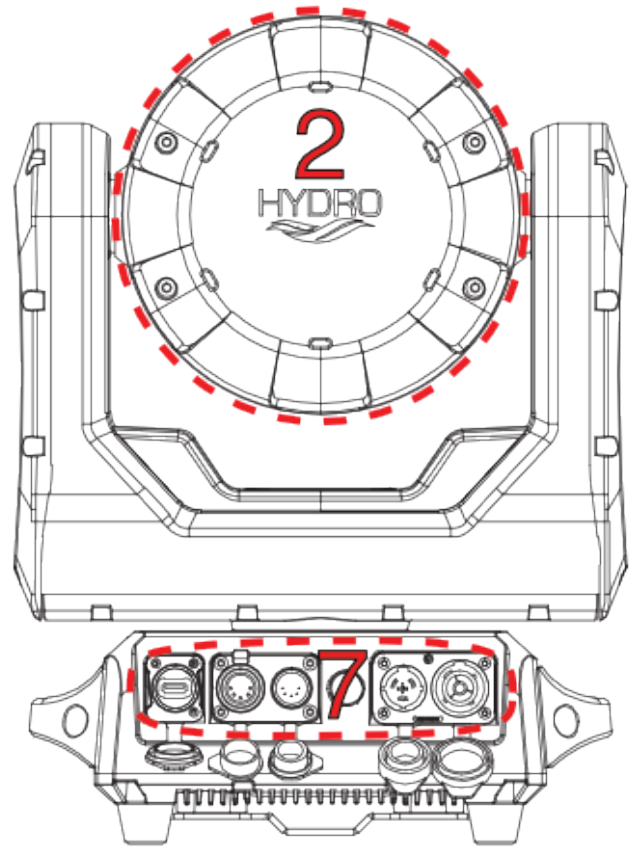
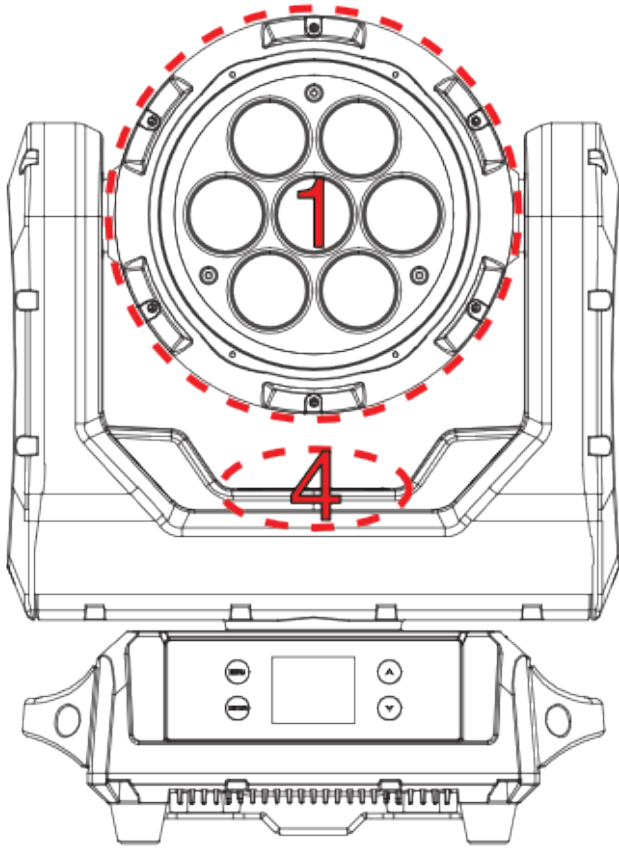

FIXTURE INSTALLATION

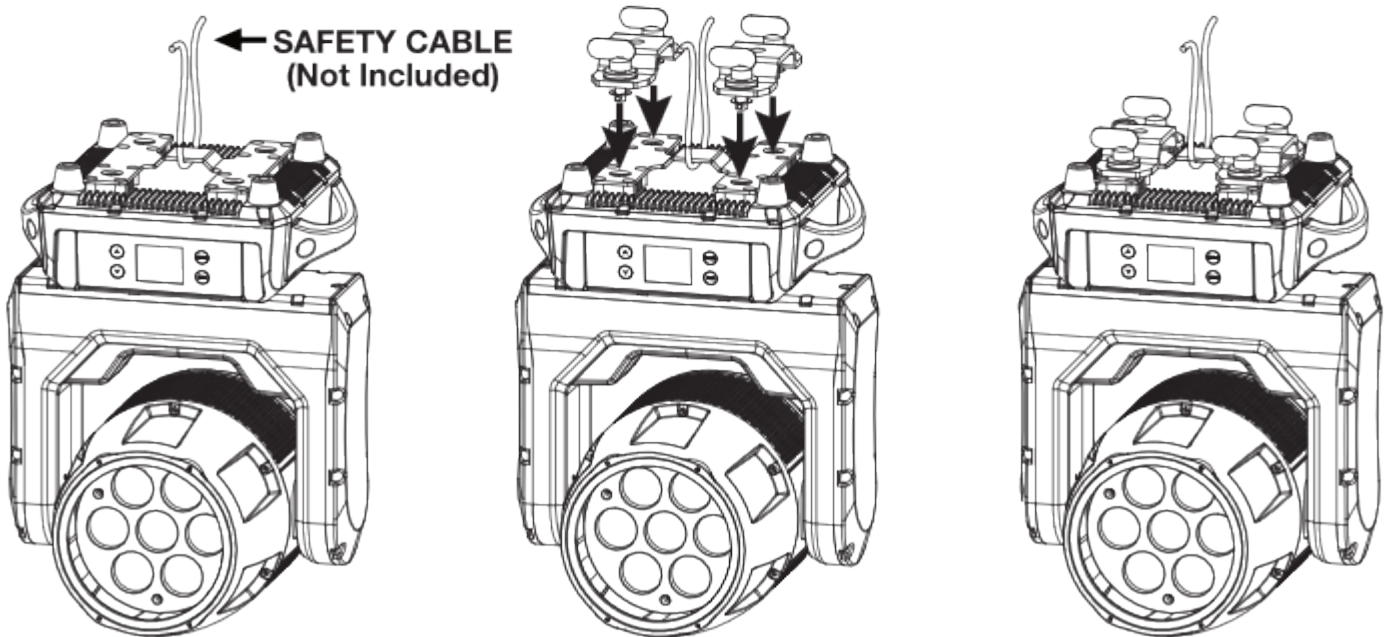
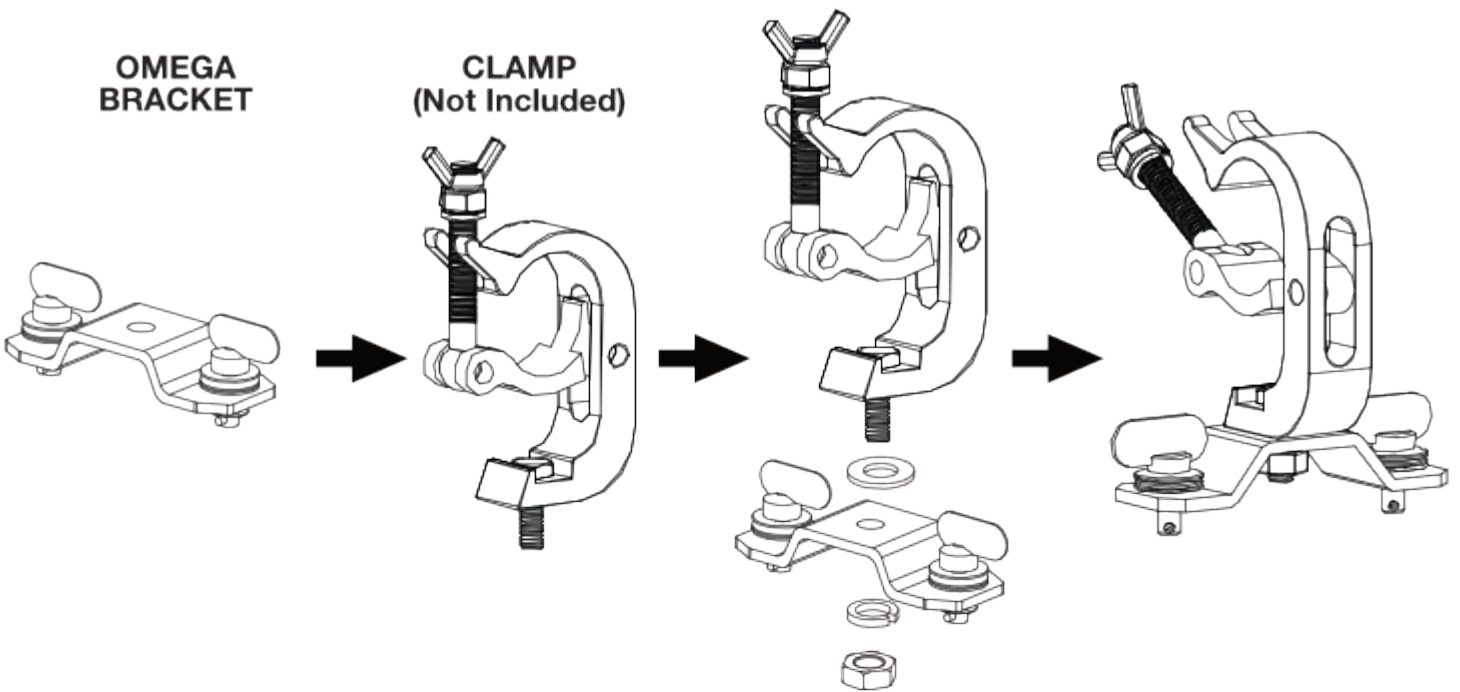

Screw one clamp via a M12 screw and nut into the Omega Bracket. Insert the quick-lock fasteners of the Omega Bracket into the respective holes of the fixture base plate. **NOTE: The clamp must be attached to the Omega Bracket before attaching the bracket to the fixture.** Tighten the quick-lock fasteners fully clockwise. Pull the safety-cable through the opening located on the bottom of the unit and over the trussing system or a safe fixation spot. Insert the end in the carabiner, and tighten the safety screw.

FIXTURE INSTALLATION

When installing the unit, the trussing or area of installation must be able to hold 10 times the weight without any deformation. When installing the unit must be secured with a secondary safety attachment, e.g. and appropriate safety cable. Never stand directly below the unit when mounting, removing, or servicing the unit.

Overhead mounting requires extensive experience, including calculating working load limits, installation material being used, and periodic safety inspection of all installation material and unit. If you lack these qualifications, do not attempt the installation yourself. These installations should be checked by a skilled person once a year.

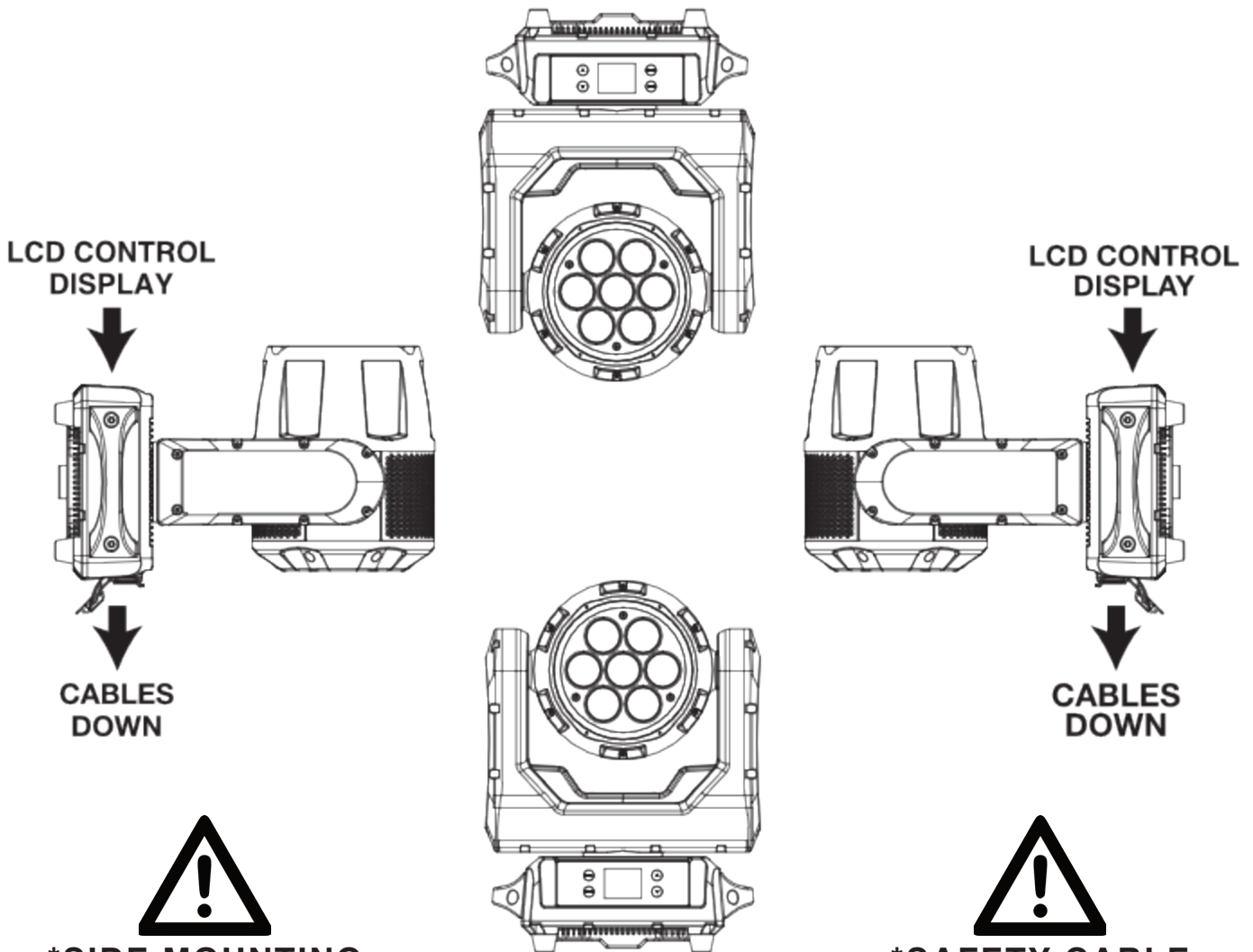

*SIDE MOUNTING

TO MAINTAIN IP65 RATING INTEGRITY, FIXTURE MUST BE INSTALLED WITH CABLES FACING THE GROUND AT ALL TIMES. WATER MUST EASILY RUN OFF AND NOT COLLECT AROUND CABLE CONNECTIONS.

*SAFETY CABLE

ALWAYS ATTACH A SAFETY CABLE WHENEVER INSTALLING THIS FIXTURE IN A SUSPENDED ENVIRONMENT TO ENSURE THE FIXTURE WILL NOT DROP IF THE CLAMP FAILS.

The Hydro Wash X7 is fully operational in three different mounting positions, hanging upside-down, mounted sideways on trussing, or set on a flat level surface. Always use and install a safety cable as a safety measure to prevent accidental damage and/or injury in the event the clamp fails. Never use the carrying handles for secondary attachment.

CONNECTIONS

ENSURE ALL CONNECTIONS AND END CAPS ARE PROPERLY SEALED WITH A DIELECTRIC GREASE (AVAILABLE AT MOST ELECTRICAL SUPPLIERS) TO PREVENT WATER CORROSION AND/OR ELECTRICAL SHORT CIRCUIT.

TO MAINTAIN IP65 RATING INTEGRITY AND PREVENT WATER FROM ENTERING THE FIXTURE, ALL UNUSED CONNECTION RUBBER CAPS MUST BE SEALED

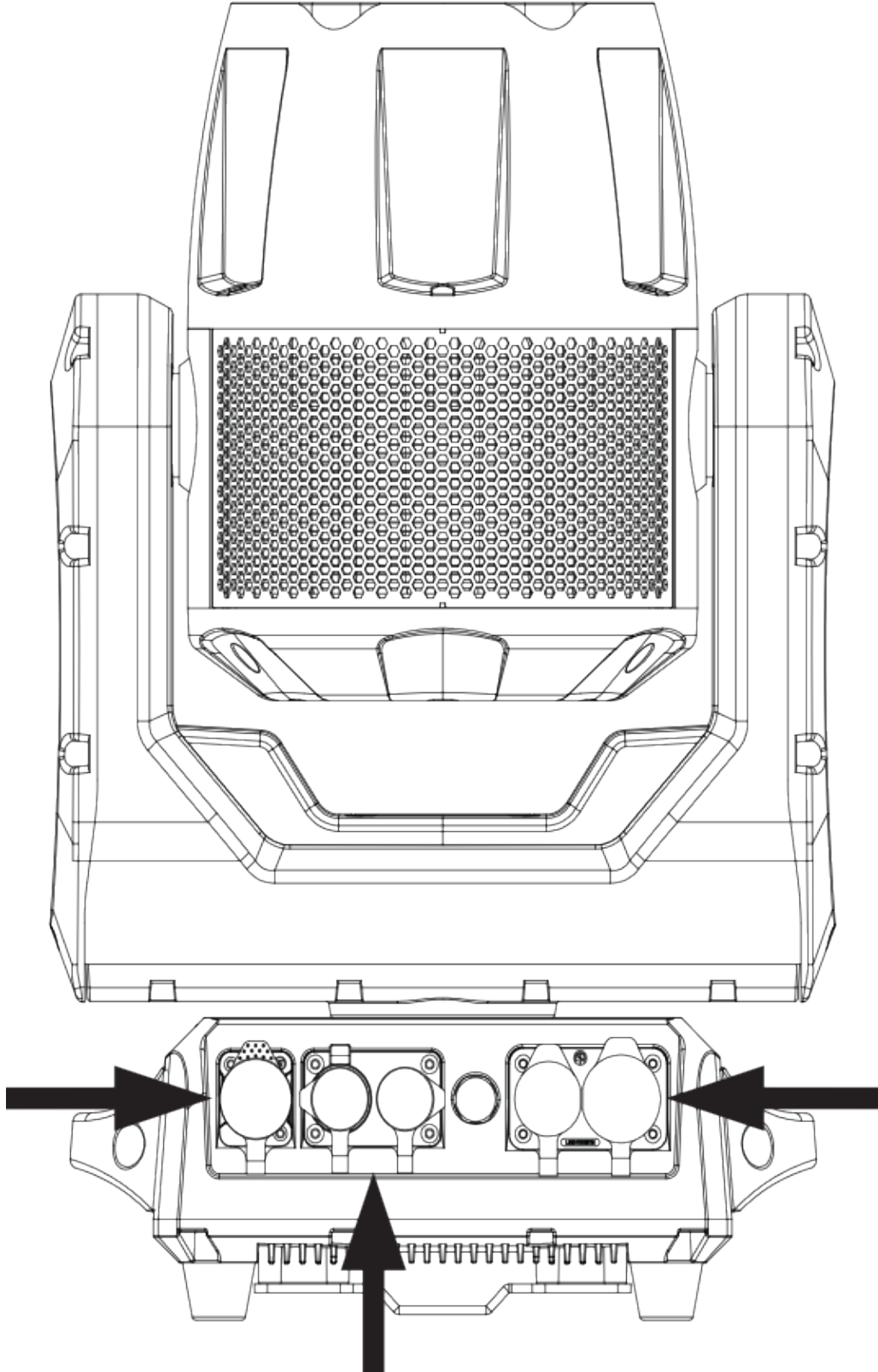

DMX SETUP

DMX-512:

DMX is short for Digital Multiplex. This is a universal protocol used as a form of communication between intelligent fixtures and controllers. A DMX controller sends DMX data instructions from the controller to the fixture. DMX data is sent as serial data that travels from fixture to fixture via the DATA “IN” and DATA “OUT” XLR terminals located on all DMX fixtures (most controllers only have a DATA “OUT” terminal).

DMX Linking:

DMX is a language allowing all makes and models of different manufactures to be linked together and operate from a single controller, as long as all fixtures and the controller are DMX compliant. To ensure proper DMX data transmission, when using several DMX fixtures try to use the shortest cable path possible. The order in which fixtures are connected in a DMX line does not influence the DMX addressing. For example; a fixture assigned a DMX address of 1 may be placed anywhere in a DMX line, at the beginning, at the end, or anywhere in the middle. When a fixture is assigned a DMX address of 1, the DMX controller knows to send DATA assigned to address 1 to that unit, no matter where it is located in the DMX chain.

DATA CABLE (DMX CABLE) REQUIREMENTS (FOR DMX AND PRIMARY/SECONDARY OPERATION):

The Hydro Wash X7 can be controlled via DMX-512 protocol. Your unit and your DMX controller requires a 5-pin XLR connector for data input and data output. We recommend Accu-Cable DMX cables. If you are making your own cables, be sure to use standard 110-120 Ohm shielded cable (This cable may be purchased at almost all pro lighting stores). Your cables should be made with a male and female XLR connector on either end of the cable. Also remember that DMX cable must be daisy chained and cannot be split.

TO MAINTAIN IP65 RATING INTEGRITY AND PREVENT WATER FROM ENTERING THE FIXTURE, ALL UNUSED CONNECTION RUBBER CAPS MUST BE SEALED AND ONLY IP65 RATED POWER AND DATE CABLES MUST BE USED.

Notice: Be sure to follow figures two and three when making your own cables. Do not use the ground lug on the XLR connector. Do not connect the cable’s shield conductor to the ground lug or allow the shield conductor to come in contact with the XLR’s outer casing. Grounding the shield could cause a short circuit and erratic behavior.

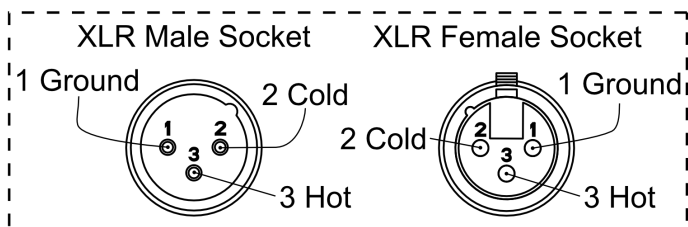
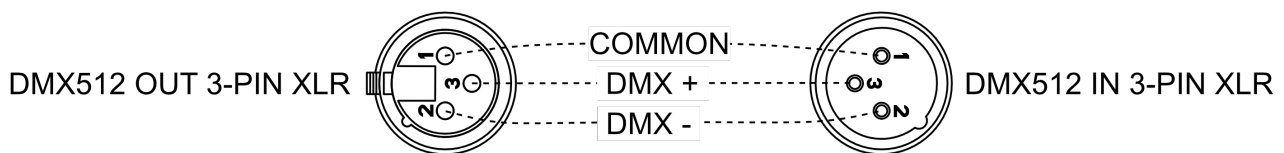

XLR Pin Configuration
Pin 1 = Ground
Pin 2 = Data Compliment (negative)
Pin 3 = Data True (positive)

DMX SETUP

SPECIAL NOTE: LINE TERMINATION

When longer runs of cable are used, you may need to use a terminator on the last unit to avoid erratic behavior. A terminator is a 110-120 ohm 1/4 watt resistor, which is connected between pins 2 and 3 of a male XLR connector (DATA + and DATA -). This unit is inserted in the female XLR connector of the last unit in your daisy chain to terminate the line. Using a cable terminator (ADJ part number Z-DMX/T) will decrease the possibilities of erratic behavior.

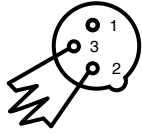

Termination reduces signal errors and avoids signal transmission problems and interference. It is always advisable to connect a DMX terminal, (Resistance 120 Ohm 1/4 W) between PIN 2 (DMX-) and PIN 3 (DMX+) of the last fixture. Figure 4

3-Pin XLR to 5-Pin XLR Conversion		
Conductor	3-Pin XLR Female (Out)	5-Pin XLR Male (In)
Ground/Sheld	Pin 1	Pin 1
Data Compliment (- signal)	Pin 2	Pin 2
Data True (+ signal)	Pin 3	Pin 3
Not Used		Do Not Use
Not Used		Do Not Use

5-Pin XLR DMX Connectors. Some manufacturers use 5-pin DMX-512 data cables for DATA transmission in place of 3-pin. 5-pin DMX fixtures may be implemented in a 3-pin DMX line. When inserting standard 5-pin data cables in to a 3-pin line a cable adapter must be used, these adapters are readily available at most electric stores. The chart below details a proper cable conversion.

DMX ADDRESSING

All fixtures should be given a DMX starting address when using a DMX controller, so the correct fixture responds to the correct control signal. This digital starting address is the channel number from which the fixture starts to “listen” to the digital control signal sent out from the DMX controller. The assignment of this starting DMX address is achieved by setting the correct DMX address on the digital control display on the fixture.

You can set the same starting address for all fixtures or a group of fixtures, or set different addresses for each individual fixture. Setting all fixtures to the same DMX address will cause all fixtures to react in the same way, in other words, changing the settings of one channel will affect all the fixtures simultaneously.

If you set each fixture to a different DMX address, each unit will start to “listen” to the channel number you have set, based on the quantity of DMX channels of each fixture. That means changing the settings of one channel will only affect the selected fixture.

In the case of the Hydro Wash X7, when in 15 Channel you should set the starting DMX address of the first unit to 1, the second unit to 16 (15 + 1), the third unit to 31 (16 + 15), and so on. (See the chart below for more details.)

Channel Mode	Unit 1 Address	Unit 2 Address	Unit 3 Address	Unit 4 Address
15 Channels	1	16	31	46
17 Channels	1	18	35	52
22 Channels	1	23	45	67
41 Channels	1	42	83	124
46 Channels	1	47	93	139

SYSTEM MENU

The fixture includes an easy to navigate system menu control panel display where all necessary settings and adjustments are made. (See image below) During normal operation, pressing the **MENU** button once will access the fixture's main menu. Once in the main menu, you can navigate through the different functions and access the sub-menus with the **UP** and **DOWN** buttons. When you reach a field that requires adjusting, press the **ENTER** button to access that field and use the **UP** and **DOWN** buttons to adjust the field. Pressing the **ENTER** button once more will confirm your setting. You may exit the main menu at any time without making any adjustments by pressing the **MENU** button.

SYSTEM LOCK/UNLOCK: When the display lock function is activated, the display and system menu will lock after 10 seconds of no activity. To **UNLOCK** the display, press and **HOLD** the **MENU** button for 10+ seconds.

While pressing the MENU button, a timer will appear at the bottom of the display indicating the passing seconds from 0-9. Once the timer reaches 9 seconds, the display will unlock allowing access to the system menu.

DO NOT RELEASE THE MENU BUTTON UNTIL THE DISPLAY IS UNLOCKED.

If the **MENU** button is released before the timer reaches 9 seconds and/or is unlocked, the display will not unlock and the time will be reset.

NOTE: The timer will not appear in the display if the lock function is disabled.



SYSTEM MENU

MAIN MENU	SUB MENU	OPTIONS / VALUES (Default Settings in BOLD)	DESCRIPTION
DMX SETTINGS	DMX Address	001-XXX	DMX Addressing
	DMX Channel Mode	15 / 17 / 22 / 41 / 46 Ch	DMX Channel Mode Selection
	No DMX Status	Hold Last / Blackout / Int Programs / Manual	DMX Lost Status
PERSONALITY	Select Signal	DMX: YES / NO	Control via DMX
		WiFly: YES / NO	Control via WiFly
		WiFly and DMX Out: YES / NO	Control via WiFly and send DMX Out via DMX cable
	Status Settings	Pan Invert: ON / OFF	Reverse Pan Motion
		Tilt Invert: ON / OFF	Reverse Tilt Motion
		P./T. Feedback: ON / OFF	Pan/Tilt Movement Feedback
		P./T. Speed: Speed 1 / Speed 2	Pan/Tilt Movement Speed
		Hibernation: Off / 01M~99M / 15M	Sleep Setting (No Activity)
	WiFly Settings	Set WiFly Channel: 00 ~14	Set WiFly Wireless Channel
		Enable / Disable WiFly	Activate / Deactivate WiFly
	Fan Settings	Head: Auto / High / Silent (Low)	Head Fan Speed Setting
		Base: Auto / High / Silent (Low)	Base Fan Speed Setting
	Dim Modes	Standard /Stage/TV/Architectural/Theatre/Stage2 Dim Speed: 0.1-0.9s ~ 1-10s	Dimming Curve Modes Dimming Speed
	LED Refresh Rate	900Hz / 1000Hz / 1100Hz / 1200Hz / 1300Hz / 1400Hz / 1500Hz / 2500Hz / 4000Hz /5000Hz / 6000Hz / 10000Hz / 15000Hz	LED Refresh Setting
	Gamma	1.0 / 2.0 / 2.2 / 2.4 / 2.6 / 2.8	Gamma Brightness
	Reset Motors	Reset All Motor: YES / NO	Reset All Motors
		Pan/Tilt Reset: YES / NO	Reset the Pan & Tilt Motors
		Zoom Reset: YES / NO	Reset the Zoom Motor
	Display	Intensity: 1~10 (Dimmest-Brightest)	Display Intensity Adjustment
		Display Invert: YES / NO	Display Inversion Display
		Screen Saver Delay: OFF~ 10M	Blackout Time
		Lock On/Off: ON / OFF	Display Control Lock
	Service (Pass Code = 50)	Calibration - Pass Code = 050	Calibration/Adjustments
USB Port Power: ON / OFF		USB Port Activation	
Update Software		Software Update	
Factory Restore: YES / NO - Pass Code = 011		Restore Factory Settings	

SYSTEM MENU

MAIN MENU	SUB MENU	OPTIONS / VALUES (Default Settings in BOLD)	DESCRIPTION
MANUAL CONTROL	Mode	001 / 002	Manual Control
	MODE 1 (001)		
	Pan	000-255	
	Tilt	000-255	
	Color	000-255	
	Red 1-7	000-255	
	Green 1-7	000-255	
	Blue 1-7	000-255	
	White 1-7	000-255	
	Color Macros	000-255	
	Shutter	000-255	
	Dimmer	000-255	
	Zoom (Wide to Narrow)	000-255	
	Spe. Func	000-255	
	MODE 2 (002)		
	Pan	000-255	
	Tilt	000-255	
	Colors	000-255	
	All Red	000-255	
	All Green	000-255	
	All Blue	000-255	
	All White	000-255	
	Color Macros	000-255	
Shutter	000-255		
Dimmer	000-255		
Zoom (Wide to Narrow)	000-255		
Spe. Func	000-255		
INTERNAL PROGRAMS	Program 0	Speed: 000~255 Fade: 000~255	Program 0 with Adjustments
	Program 1	Speed: 000~255 Fade: 000~255	Program 1 with Adjustments
	Program 2	Speed: 000~255 Fade: 000~255	Program 2 with Adjustments
	Program 3	Speed: 000~255 Fade: 000~255	Program 3 with Adjustments
	Program 4	Speed: 000~255 Fade: 000~255	Program 4 with Adjustments
Target Mode	Target Mode	Mode 0 / Mode 1 / Mode 2 / Mode 3 / Mode 4	Target Mode

SYSTEM MENU

MAIN MENU	SUB MENU	OPTIONS / VALUES (Default Settings in BOLD)	DESCRIPTION	
Information	Fixture Life Time	Power On Time - XXXXXX Hours	Total Running Time (Not Resettable)	
		P-On Time-R - XXXXXX Hours	Total Running Time (Resettable)	
		P-On Time Reset - Pass Code = 050	Reset Total Running Time	
	Total LED Time	LED On Time - XXXXXX Hours	Total LED On Running Time (Not Resettable)	
		LED On Time-R - XXXXXX Hours	LED On Running Time (Resettable)	
		LED On Time Reset - Pass Code = 050	Reset LED Running Time	
	Fixture Temps	LEDs	Current: XXX °F / XXX °C	Current LED Temperature
			Max Resettable: XXX °F / XXX °C	Maximum Temperature(1) Reached (Resettable) (See Note 1)
			Max Not Resettable: XXX °F / XXX °C	Maximum Temperature(2) Reached (Not Resettable) (See Note 2)
		Head	Current: XXX °F / XXX °C	Current Head Temperature
			Max Resettable: XXX °F / XXX °C	Maximum Temperature(1) Reached (Resettable) (See Note 1)
			Max Not Resettable: XXX °F / XXX °C	Maximum Temperature(2) Reached (Not Resettable) (See Note 2)
		Base	Current: XXX °F / XXX °C	Current Base Temperature
			Max Resettable: XXX °F / XXX °C	Maximum Temperature(1) Reached (Resettable) (See Note 1)
			Max Not Resettable: XXX °F / XXX °C	Maximum Temperature(2) Reached (Not Resettable) (See Note 2)
		Reset LED Temp: Pass Code = 050	Reset LED Temperature (Max Resettable)	
		Reset Head Temp: Pass Code = 050	Reset Head Temperature (Max Resettable)	
		Reset Base Temp: Pass Code = 050	Reset Head Temperature (Max Resettable)	
		Humidity	Head: XXX%	Current Head Humidity
			Base: XXX%	Current Base Humidity
		Fan Info. (RPM)	LED Fan: XXXX	Current LED Fan Speed
	Base Fan: XXXX		Current Base Fan Speed	
	Arm Fan: XXXX		Current Arm Fan Speed	
	DMX Values(3) (See Note 3)	Pan / Pan Fine / Tilt / Tilt Fine / Color / Color Macros / Red 1-7 / Green 1-7 / Blue 1-7 / White 1-7 / Shutter / Dimmer / Dimmer Fine / Zoom / Dimmer Modes / P/T Speed / Spe. Func	Current DMX Values	
	Error Logs	Fixture Errors (Listed Errors One by One)	Last 10 Fixture Error Codes	
		Reset Error Log: Yes / No (Pass Code = 050)	Clear the Error Log	
	Max Temp LED ON	32~169°F, 99°F(4) / 0~76°C, 37°C(4) (See Note 4 below)	Fixture Temp. (LED On)	
	High Temp LED OFF	170°F, 99°F(5) / 77°C, 37°C(5) (See Note 5 below)	Fixture Temp. (LED Off)	
	Software Version	VX.X	Current Software Version	

SYSTEM MENU NOTES:

- (1) Current Maximum Temperature - Maximum temp. that has been recorded, before reset and after reset.
- (2) Maximum Temperature - Overall maximum temp. that has been recorded. (Not Resettable)
- (3) DMX Value settings depend on the DMX Channel mode the fixture is set to.
- (4) Max Temp LED ON - Normal Operating Temperature
- (5) Max Temp LED OFF - Normal Operating Temperature

SYSTEM MENU

DMX SETTINGS - The submenus listed under **DMX SETTINGS** are as follows: **DMX Address**, **DMX Channel Mode**, and **No DMX Status**.

- **DMX ADDRESS** - In this submenu you can find and set your desired DMX address.
- **DMX CHANNEL MODE** - In this submenu you can find and set your desired DMX channel mode.
- **NO DMX STATUS** - This submenu setting is used as a precaution mode in case the DMX signal is lost or interrupted. The operating mode chosen in this submenu is the running mode the fixture will go into when the DMX signal is lost. Listed below are the 3 modes.
 - **Hold Last** - This setting will have the fixture stay in the last DMX setup.
 - **Blackout** - This setting will have the fixture automatically go into stand by mode.
 - **Int Programs** - This setting will have the fixture go into Internal Programs mode.
 - **Manual** - This setting will go into the current manual control set up. See **MANUAL CONTROL**.

PERSONALITY - The submenus listed under **PERSONALITY** are as follows: **Select Signal**, **Status Settings**, **WiFly Settings**, **Fan Settings**, **Dim Modes**, **LED Refresh Rate**, **Gamma**, **Reset Motors**, **Display**, and **Service**.

- **SELECT SIGNAL** - In this submenu you can select your desired DMX control mode:
 - **DMX** - Control the unit via DMX cable connection.
 - **WiFly** - Control the unit via WiFly.
 - **WiFly and DMX Out** - Control the unit via WiFly connection. The DMX signal is sent to the next unit via DMX cable.
- **STATUS SETTINGS** - In this submenu you are able to access and adjust/change: Pan Invert, Tilt Invert, P./T. Feedback, P./T. Speed, and Hibernation.
- **WIFLY SETTINGS** - In this submenu you are able to access and adjust/change: WiFly Channel setting and Enable/Disable WiFly.
- **FAN SETTINGS** - In this submenu you are able to select your desired fan speed settings for both the head and base fans.
- **DIM MODES** - In this submenu you are able to select your desired dimmer mode and adjust the dimming speed time. See page 34 for the dimmer curve chart.
- **LED REFRESH RATE** - In this submenu you are able to select your desired LED refresh rate.
- **GAMMA** - In this submenu you are able to select your desired gamma setting.
- **RESET MOTORS** - In this submenu you are able to reset selected motors.
- **DISPLAY** - In this submenu you are able to access and adjust/change the backlight intensity, display inversion, screen saver display time, and display lock function.
- **SERVICE** - In this submenu you are able to access the calibration adjustment, USB port power on/off, software update, and restore the factory settings.

SYSTEM MENU

MANUAL CONTROL - This menu is for manual testing and manual control. Under **MANUAL CONTROL**, the fixture has two control modes; “**MODE 1**” and “**MODE 2**”.

NOTE: NO DMX STATUS must be set to “Manual” when using Manual Control.

INTERNAL PROGRAMS - This menu allows you to select 1 of 4 (0-4 internal programs to run. Program speed and fade speed are adjustable. The selected program will also run when “**Int Program.**” is selected under the “**NO DMX STATUS**” setting.

TARGET MODE - Target mode is a restrictive pan/tilt control limiting the movement to a certain degree. See diagram of the Target Mode Movements.

INFORMATION - The submenus listed under **INFORMATION** are as follows: **Fixture Life Time, Total LED Time, Fixture Temps, Humidity, Fan Info. (RPM), DMX Values, Error Logs, Max Temp LED ON, High Temp LED OFF, and Software Version.**

- **FIXTURE LIFE TIME**

- **Power On Time** -The **TOTAL** power ON running time of the unit is displayed. This time **CANNOT** be reset.
- **P-On Time-R** - The **CURRENT** power ON running time of the unit is displayed. This running time may not be the same as the total power **ON** running time displayed under “**Power On Time**”. This time **CAN** be reset. **NOTE: The displayed time represents the current power ON time since the last reset.**
- **P-On Time Reset** - Reset the **CURRENT** power ON running time that is displayed under “**P-On Time-R**”.

- **TOTAL LED TIME**

- **LED On Time** - The **TOTAL LED ON** time is displayed. This total **LED ON** time **CANNOT** be reset. **NOTE: The displayed time represents the TOTAL LED ON time.**
- **LED On Time-R** - The **CURRENT LED ON** running time is displayed. This running time may not be the same as the total **LED ON** time displayed under “**LED On Time**”. This total **LED ON** time **CAN** be reset. **NOTE: The displayed time represents the CURRENT LED ON time since the last reset.**
- **LED On Time Reset** - With this function you can reset the **CURRENT LED ON** time that is displayed under “**LED On Time-R**”.

SYSTEM MENU

- **FIXTURE TEMPS**

- **LEDs**

- **Current** - Current temperature of the LED's is displayed.

- **Max Resettable** - Maximum LED temperature that has been recorded, before reset and after reset. **(Resettable)**

- **Max Not Resettable** - Overall maximum LED temperature that has been recorded. **(Not Resettable)**

- **Head**

- **Current** - Current temperature of the head is displayed.

- **Max Resettable** - Maximum base temperature that has been recorded, before reset and after reset. **(Resettable)**

- **Max Not Resettable** - Overall maximum moving head temperature that has been recorded. **(Not Resettable)**

- **Base**

- **Current** - Current temperature of the base is displayed.

- **Max Resettable** - Maximum base temperature that has been recorded, before reset and after reset. **(Resettable)**

- **Max Not Resettable** - Overall maximum moving base temperature that has been recorded. **(Not Resettable)**

- **Reset LED Temp** - Reset the LED temperature reading.

- **Reset head Temp** - Reset the head temperature reading.

- **Reset Base Temp** - Reset the base temperature reading.

- **HUMIDITY**

- **Head Humidity** - The current humidity of the moving head is displayed.

- **Base Humidity** - The current humidity of the base is displayed.

- **FAN INFO. (RPM)** - In this submenu the current LED, base, and arm fan speed will be displayed.

- **DMX VALUES** - Displays the DMX values of any DMX channel that is currently in use. **NOTE: DMX value options depend on the current DMX channel mode setting.**

- **ERROR LOGS** - In this submenu you are able to check any unit errors as well as clear the errorlog.

- **MAX TEMP LED ON** - In this submenu you are able to check the normal operating temperatures as well as the current temperature of the fixture.

- **HIGH TEMP LED OFF** - In this submenu you are able to check the normal operating temperatures as well as the current temperature of the fixture.

- **SOFTWARE VERSION** - Current software version is displayed.

WIFLY CONTROL



BEFORE SETTING THE WIRELESS CHANNEL ON ANY WIFLY FIXTURE, MAKE SURE THE SOURCE WIFLY WIRELESS DMX TRANSCEIVER DEVICE IS OFF.

With this feature you are able to control the unit with DMX without the need of XLR cables. Your DMX controller must be connected to a **ADJ WiFly** Transceiver to use this function. You are able to communicate up to 2500 feet/760 meters (open line of sight).

1. Ensure the source **WiFly** wireless DMX Transceiver device is powered **OFF**.
2. Power **ON** the fixture and using the control panel scroll to the **PERSONALITY** menu and press **ENTER**. Use the **UP** and **DOWN** buttons to highlight the **WIFLY SETTINGS** submenu and press **ENTER**.
3. Using the **UP** and **DOWN** buttons, highlight **ENABLE/DISABLE WIFLY**. Press the **ENTER** button to toggle between **ENABLE & DISABLE**. Press **ENTER** so that “**ENABLE**” is displayed.
4. Next highlight **SET WIFLY CHANNEL** and press **ENTER**. Use the **UP** and **DOWN** buttons to find your desired **WiFly** address and press **ENTER** to confirm.

NOTE: Erratic fixture movement may occur if other **WiFly** wireless DMX products are in use in the same area and are using the same **WiFly** wireless channel. When **WiFly** is enabled, the fixture may immediately start to respond to the DMX wireless signal from another **WiFly** wireless **DMX** Transceiver. Make sure to know what **WiFly** wireless channels are being used in the area where the fixture is being used.

ADJ WIFLY WIRELESS TRANSCEIVER only has 0-14 wireless channels, NO CH 15.

5. Set your desired DMX address in the **DMX ADDRESS** submenu of the **DMX SETTINGS** main system menu. Set your desired DMX channel mode in the **DMX CHANNEL MODE** submenu of the **DMX SETTINGS** main system menu.
6. Repeat this process for all **WiFly** compatible fixtures in the **WiFly** wireless network, making sure all fixtures are assigned the same **WiFly** wireless channel.
7. After all fixtures in the **WiFly** wireless network have been set to the same **WiFly** wireless channel and powered **ON**, power **ON** the source **WiFly** DMX Transceiver device.
8. Test all fixtures connected to the **WiFly** wireless network to confirm proper functionality.

WIRELESS WIFLY INSTALLATION LOCATION GUIDELINES

Wireless DMX signal can penetrate walls, glass, metal, and most objects. However, there are many factors that can affect and/or interrupt the wireless DMX signal, one of which is people. Therefore, it is highly recommended to position the wireless antenna a minimum of 9.8 ft. (3m) above audiences and/or above ground level. Careful planning and testing of the selected installation location is critical to ensure optimum and reliable wireless DMX operation.

**9.8 ft (3m)
Above Ground**

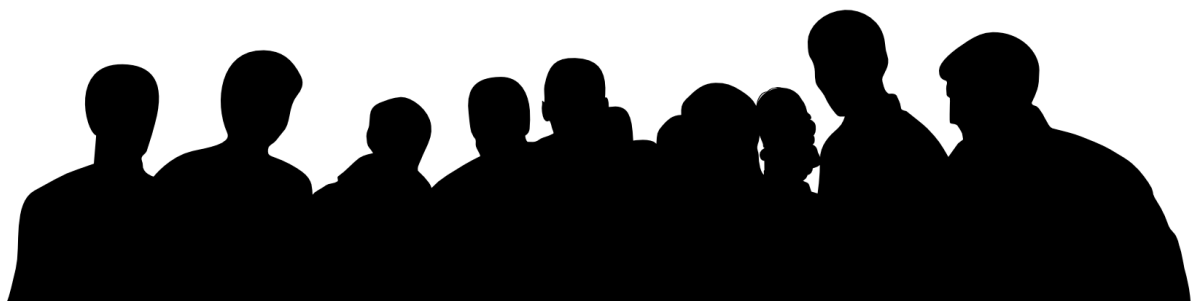
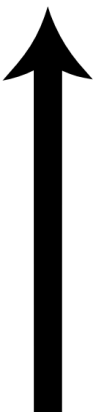

DMX TRAITS

CHANNEL					DMX VALUES	FUNCTION
15CH	17CH	22CH	41CH	46CH		
1	1	1	1	1	000 - 255	k 0° to 540°
	2	2	2	2	000 - 255	Pan Fine
2	3	3	3	3	000 - 255	Tilt, 0° to 240°
	4	4	4	4	000 - 255	Tilt Fine
3	5	5	5	5		Color
					000 - 002	Open
					003 - 004	Color1
					005 - 006	Color2
					007 - 008	Color3
					009 - 010	Color4
					011 - 012	Color5
					013 - 014	Color6
					015 - 016	Color7
					017 - 018	Color8
					019 - 021	Color9
					022 - 023	Color10
					024 - 025	Color11
					026 - 027	Color12
					028 - 029	Color13
					030 - 031	Color14
					032 - 033	Color15
					034 - 035	Color16
					036 - 037	Color17
					038 - 039	Color18
					040 - 042	Color19
					043 - 044	Color20
					045 - 046	Color21
					047 - 048	Color22
					049 - 050	Color23
051 - 052	Color24					
053 - 054	Color25					
055 - 056	Color26					
057 - 058	Color27					
059 - 060	Color28					
061 - 063	Color29					
064 - 127	Index					
128 - 189	Clockwise Rotation, fast to slow					
190 - 193	Stop					
194 - 255	Counter-clockwise Rotation, slow to fast					

DMX TRAITS

CHANNEL					DMX VALUES	FUNCTION
15CH	17CH	22CH	41CH	46CH		
4	6	6	6	6	000 - 255	Color Macros (see Color Macros Chart section of this manual)
5	7	7			000 - 255	Red , 0% to 100%
6	8	8			000 - 255	Green , 0% to 100%
7	9	9			000 - 255	Blue , 0% to 100%
8	10	10			000 - 255	White , 0% to 100%
			7	7	000 - 255	Red1 , 0% to 100%
			8	8	000 - 255	Green1 , 0% to 100%
			9	9	000 - 255	Blue1 , 0% to 100%
			10	10	000 - 255	White1 , 0% to 100%
			11	11	000 - 255	Red2 , 0% to 100%
			12	12	000 - 255	Green2 , 0% to 100%
			13	13	000 - 255	Blue2 , 0% to 100%
			14	14	000 - 255	White2 , 0% to 100%
			15	15	000 - 255	Red3 , 0% to 100%
			16	16	000 - 255	Green3 , 0% to 100%
			17	17	000 - 255	Blue3 , 0% to 100%
			18	18	000 - 255	White3 , 0% to 100%
			19	19	000 - 255	Red4 , 0% to 100%
			20	20	000 - 255	Green4 , 0% to 100%
			21	21	000 - 255	Blue4 , 0% to 100%
			22	22	000 - 255	White4 , 0% to 100%
			23	23	000 - 255	Red5 , 0% to 100%
			24	24	000 - 255	Green5 , 0% to 100%
			25	25	000 - 255	Blue5 , 0% to 100%
			26	26	000 - 255	White5 , 0% to 100%
			27	27	000 - 255	Red6 , 0% to 100%
			28	28	000 - 255	Green6 , 0% to 100%
			29	29	000 - 255	Blue6 , 0% to 100%
			30	30	000 - 255	White6 , 0% to 100%
			3	31	000 - 255	Red7 , 0% to 100%
			32	32	000 - 255	Green7 , 0% to 100%
			33	33	000 - 255	Blue7 , 0% to 100%
			34	34	000 - 255	White7 , 0% to 100%
		11		35	000 - 255	Color Temperature , 2700K to 7000K linear

DMX TRAITS

CHANNEL					DMX VALUES	FUNCTION	
15CH	17CH	22CH	41CH	46CH			
		12		36		Chase Patterns	
						000 - 014	Off
						015 - 030	Chase 1
						031 - 046	Chase 2
						047 - 062	Chase 3
						063 - 078	Chase 4
						079 - 094	Chase 5
						095 - 110	Chase 6
						111 - 126	Chase 7
						127 - 142	Chase 8
						143 - 158	Chase 9
						159 - 174	Chase 10
						175 - 190	Chase 11
						191 - 206	Chase 12
						207 - 222	Chase 13
				223 - 238	Chase 14		
				239 - 255	Chase 15		
		13		37		Chase Speed	
						000 - 125	Backward, fast to slow
						126 - 130	Stop
				131 - 255	Forward, slow to fast		
		14		38	000 - 255	Chase Fade	
9	11	15	35	39		Shutter	
					000 - 031	Shutter Closed	
					032 - 063	Shutter Open	
					064 - 095	Strobe Effect, slow to fast	
					096 - 127	Shutter Open	
					128 - 159	Pulse effect in sequences	
					160 - 191	Shutter Open	
					192 - 223	Random strobe effect, slow to fast	
224 - 255	Shutter Open						
10	12	16	36	40	000 - 255	Dimmer , 0% to 100%	
11	13	17	37	41	000 - 255	Dimmer Fine	
12	14	18	38	42	000 - 255	Zoom , wide to narrow	

DMX TRAITS

CHANNEL					DMX VALUES	FUNCTION
15CH	17CH	22CH	41CH	46CH		
13	15		39			Dim Modes (15-, 17-, and 41-channel)
					000 - 020	Standard
					021 - 040	Stage
					041 - 060	TV
					061 - 080	Architectural
					081 - 100	Theatre
					101 - 120	Stage 2
					121 - 140	Dim Speed, fast to slow (0.1s to 10s)
					141 - 255	Default to unit setting
		19		43		Dim Modes (22- and 46-channel modes)
					000 - 020	Default to unit setting
					021 - 040	Standard
					041 - 060	Stage
					061 - 080	TV
					081 - 100	Architectural
					101 - 120	Theatre
					121 - 140	Stage 2
					141 - 160	Dim Speed, fast to slow (0.1s to 10s)
161 - 255	Default to unit setting					
		20		44		Dim Curves
					000 - 020	Square
					021 - 040	Linear
					041 - 060	Inv. Squa.
					061 - 080	S. Curve
081 - 255	No function					
14	16	21	40	45	000 - 255	Pan/Tilt Speed , fast to slow
15	17	22	41	46		Special Functions
					000 - 010	Default LED Refresh Rate (1200 Hz)
					011	900 Hz LED Refresh Rate
					012	1000 Hz LED Refresh Rate
					013	1100 Hz LED Refresh Rate
					014	1300 Hz LED Refresh Rate
					015	1400 Hz LED Refresh Rate
					016	1500 Hz LED Refresh Rate
017	2500 Hz LED Refresh Rate					

DMX TRAITS

CHANNEL					DMX VALUES	FUNCTION
15CH	17CH	22CH	41CH	46CH		
15	17	22	41	46		Special Functions (continued)
					018	4000 Hz LED Refresh Rate
					019	5000 Hz LED Refresh Rate
					020	6000 Hz LED Refresh Rate
					021	10,000 Hz LED Refresh Rate
					022	15,000 Hz LED Refresh Rate
					023	Default to unit setting
					024 - 079	No function
					080 - 089	Enable blackout while pan/tilt moving
					090 - 099	Disable blackout while pan/tilt moving
					100 - 139	No function
					140 - 149	Pan/tilt reset
					150 - 159	Zoom reset
					160 - 199	No function
					200 - 209	All reset
210 - 255	No function					

COLOR MACRO CHART

Color No.	DMX Value	RGBW COLOR INTENSITY				Color No.	DMX Value	RGBW COLOR INTENSITY			
		RED	GREEN	BLUE	WHITE			RED	GREEN	BLUE	WHITE
OFF	0	0	0	0	0	Color33	129-132	255	206	143	0
Color1	1-4	80	255	234	80	Color34	133-136	254	177	153	0
Color2	5-8	80	255	164	80	Color35	137-140	254	192	138	0
Color3	9-12	77	255	112	77	Color36	141-144	254	165	98	0
Color4	13-16	117	255	83	83	Color37	145-148	254	121	0	0
Color5	17-20	160	255	77	77	Color38	149-152	176	17	0	00
Color6	21-24	223	255	83	83	Color39	153-156	96	0	11	0
Color7	25-28	255	243	77	77	Color40	157-160	234	139	171	0
Color8	29-32	255	200	74	74	Color41	161-164	224	5	97	0
Color9	33-36	255	166	77	77	Color42	165-168	175	77	173	0
Color10	37-40	255	125	74	74	Color43	169-172	119	130	199	0
Color11	41-44	255	97	77	74	Color44	173-176	147	164	212	0
Color12	45-48	255	71	77	71	Color45	177-180	88	2	163	0
Color13	49-52	255	83	134	83	Color46	181-184	0	38	86	0
Color14	53-56	255	93	182	93	Color47	185-188	0	142	208	0
Color15	57-60	255	96	236	96	Color48	189-192	52	148	209	0
Color16	61-64	238	93	255	93	Color49	193-196	1	134	201	0
Color17	65-68	196	87	255	87	Color50	197-200	0	145	212	0
Color18	69-72	150	90	255	90	Color51	201-204	0	121	192	0
Color19	73-76	100	77	255	77	Color52	205-208	0	129	184	0
Color20	77-80	77	100	255	77	Color53	209-212	0	83	115	0
Color21	81-84	67	148	255	67	Color54	213-216	0	97	166	0
Color22	85-88	77	195	255	77	Color55	217-220	1	100	167	0
Color23	89-92	77	234	255	77	Color56	221-224	0	40	86	0
Color24	93-96	158	255	144	144	Color57	225-228	209	219	182	0
Color25	97-100	255	251	153	153	Color58	229-232	42	165	85	0
Color26	101-104	255	175	147	147	Color59	233-236	0	46	35	0
Color27	105-108	255	138	186	138	Color60	237-240	8	107	222	0
Color28	109-112	255	147	251	147	Color61	241-244	107	156	231	0
Color29	113-116	151	138	255	138	Color62	245-248	165	198	247	0
Color30	117-120	151	138	255	138	Color63	249-252	0	0	189	0
Color31	121-124	138	169	255	138	Color64	253-255	255	255	255	0
Color32	125-128	255	255	255	255	Color65					

TARGET MODES

Mode 0: Pan Movement Range: 540°

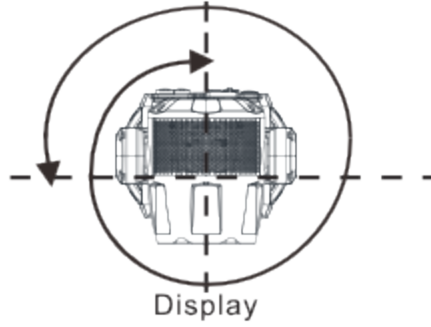

Tilt Movement Range: 270°

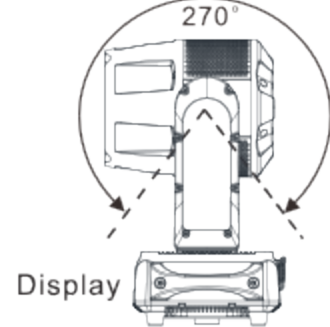

Mode 1: Pan Movement Range: 90°

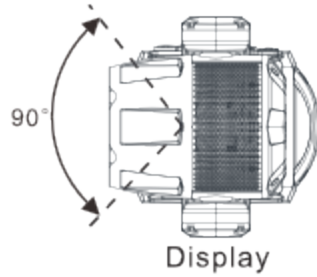

Tilt Movement Range: 135°

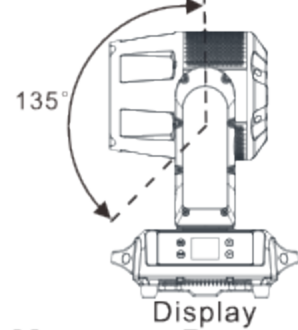

Mode 2: Pan Movement Range: 90°

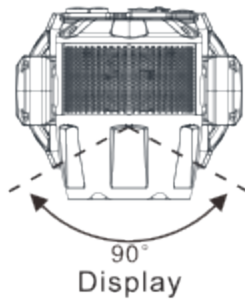

Tilt Movement Range: 135°

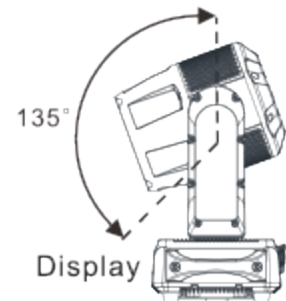

Mode 3: Pan Movement Range: 90°

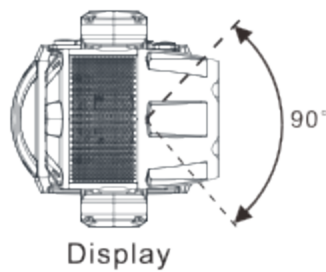

Tilt Movement Range: 135°

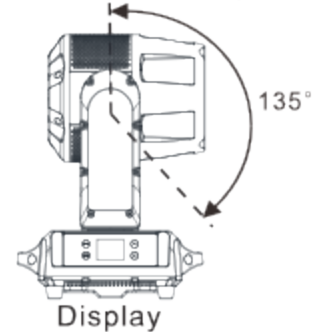

Mode 4: Pan Movement Range: 90°

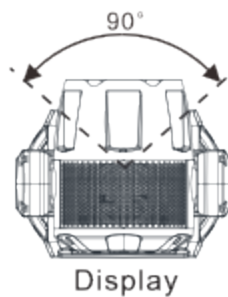

Tilt Movement Range: 135°

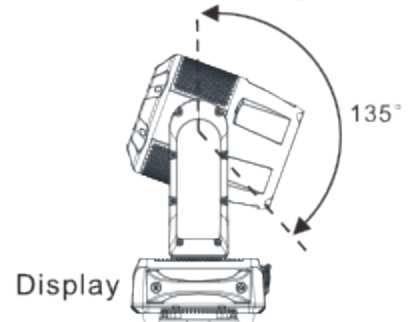

DIMMER CURVE CHART

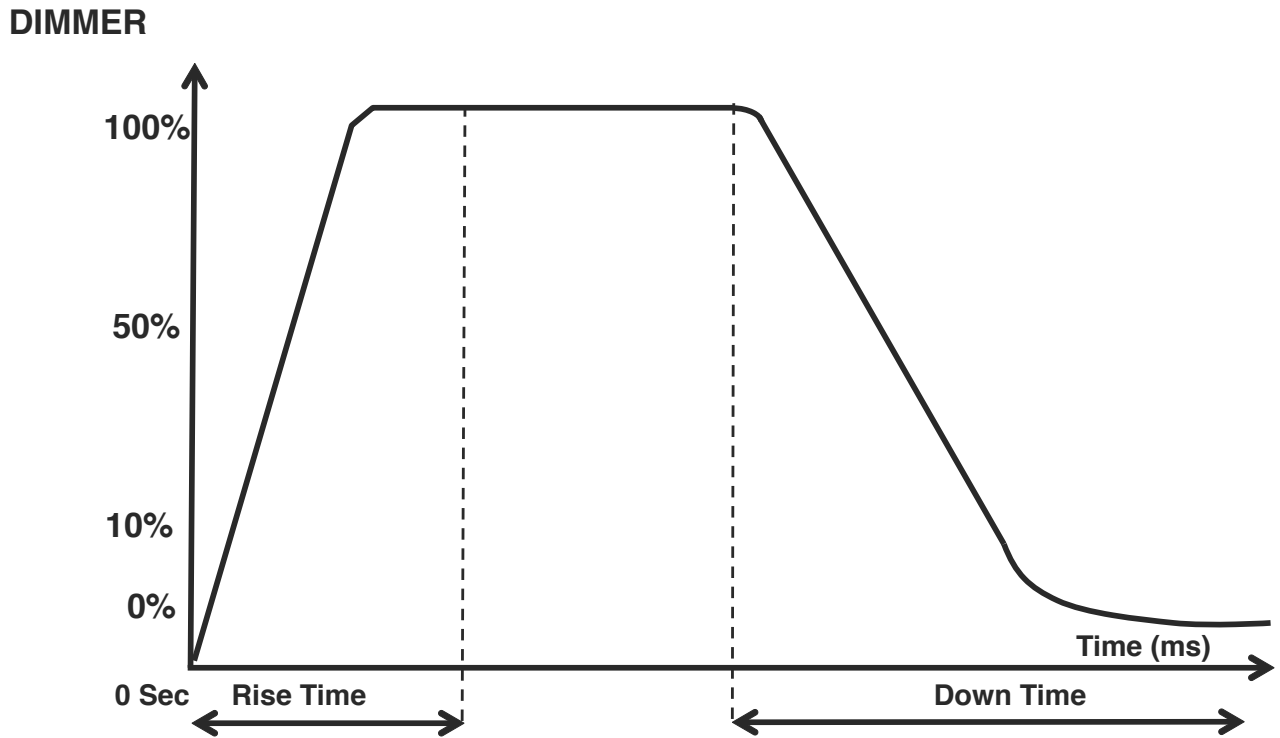

Dimming Curve Ramp Effect	0 sec Fade Time		1 sec Fade Time	
	Rise Time (ms)	Down Time (ms)	Rise Time (ms)	Down Time (ms)
Standard (default)	0	0	0	0
Stage	780	1100	1540	1660
TV	1180	1520	1860	1940
Architectural	1380	1730	2040	2120
Theatre	1580	1940	2230	2280

ERROR CODES

	PRINT ERROR MESSAGE	DESCRIPTION
1	CPU-B Error	CPU-B Error
2	CPU-C Error	CPU-C Error
3	CPU-D Error	CPU-D Error
4	Pan Reset Error	Pan: Reset Error
5	Pan Encode Error	Pan: Encode Error
6	Tilt Reset Error	Tilt: Reset Error
7	Tilt Encode Error	Tilt: Encode Error
8	Zoom Reset Error	Zoom: Reset Error
9	HeadFan Start Error	HeadFan can't start
10	HeadFan Stop Error	HeadFan can't stop
11	HeadFan speed too fast	HeadFan speed too fast
12	HeadFan speed too slow	HeadFan speed too slow
13	BaseFan Start Error	BaseFan can't start
14	BaseFan Stop Error	BaseFan can't stop
15	BaseFan speed too fast	BaseFan speed too fast
16	BaseFan speed too slow	BaseFan speed too slow
17	ArmFan Start Error	ArmFan can't start
18	ArmFan Stop Error	ArmFan can't stop
19	LED Temp: Too High	LED Temp: Too High
20	LED Temp Error	LED Temp Error

UPDATING SOFTWARE

ONLY QUALIFIED TECHNICIANS SHOULD PERFORM THIS FUNCTION! NOTE ALL MENU SETTINGS BEFORE UPDATING SOFTWARE! FIXTURE SOFTWARE CAN NOT BE DOWNGRADED! DOWNLOAD FIXTURE SOFTWARE TO PC ONLY! (NO MAC SUPPORT) PLEASE NOTE, UP TO 32 UNITS CAN BE DAISY CHAINED TOGETHER AND UPDATED AT THE SAME TIME.

PLEASE CONTACT ADJ CUSTOMER SERVICE FOR FURTHER INFORMATION.

1. Contact ADJ Customer Service to obtain the software update files.
2. Copy the software files to a compatible USB flash drive.
NOTE: MAKE SURE THESE SOFTWARE FILES ARE THE ONLY FILES LOADED ONTO THE USB FLASH DRIVE.
3. Disconnect DMX and WiFly connections and power the fixture ON.
4. Insert the USB flash drive into the **SERVICE PORT** located on the rear panel of the unit.
5. Locate **PERSONALITY** within the system menu and press **ENTER**. Scroll to the **SERVICE** submenu and press **ENTER**. Enter the passcode **50** to gain access.
6. Scroll to the **USB PORT POWER** setting and activate the USB service port by selecting **ON**.
NOTE: The USB port is OFF by default.
7. After activating the USB port, scroll to **UPDATE SOFTWARE** and press **ENTER**.
8. Two (2) software files will be displayed as downloaded earlier. Highlight the first file and press **ENTER**. Select YES to begin the first of two updating processes. Once **YES** is selected the display will show **Updating, Please wait...**. A percentage bar will also be displayed.
9. After the first update is complete, the fixture will run a software check (this can take some time).
10. After the software check is complete, the fixture will perform a reset.
11. Once the reset is complete, scroll to the **PERSONALITY** menu again and press **ENTER**. Scroll to the **SERVICE** submenu and press **ENTER**. Enter the passcode **50** to gain access.
12. Reactivate the USB port power if necessary.
13. Scroll to **UPDATE SOFTWARE** setting again and press **ENTER**.
14. Highlight the second file this time and press **ENTER**. Select YES to begin the second and final updating process. Once YES is selected the display will show **Updating, Please wait...**. A percentage bar will also be displayed.
15. After the second update is complete, the fixture will run a software check again.
16. After the software check is complete, the fixture will perform another reset.
17. Remove the USB flash drive.
18. After the reset process is complete check the new software version to confirm it is updated to the most recent software.

MULTIPLE UNIT POWER LINKING

With this feature you can connect the fixtures to one another using the power cable input and output sockets.

NOTE: USE CAUTION WHEN POWER LINKING OTHER FIXTURES AS THE POWER CONSUMPTION OF OTHER MODEL FIXTURES MAY EXCEED THE MAX POWER OUTPUT ON THIS FIXTURE! CHECK SILK SCREEN FOR MAX AMPS.

SPECIFICATIONS

Light Source:

- 7x Osram 40W RGBW (4-IN-1) LEDs

Features:

- IP65 outdoor rated – protects fixture from dust, sand, moisture and liquid.
Note: This fixture is intended for temporary outdoor use only!
- Motorized Zoom: 6 ~ 40-degrees
- Firmware Upgrade: Update via IP65 USB port (with rubber protective covers over connections)
- Antenna Range: 98.42ft (30m)

Construction:

- Color display with touch buttons
- Data In/Out: 5-pin DMX IP65 (with rubber protective covers over connections)
- Power In/Out: locking IP65 (with rubber protective covers over connections)
- All metal case design

Control:

- WiFLY Wireless DMX built-in (Up to 2,500 ft / 700M line of sight)
- 3 DMX channel modes: 15, 17 & 41 channels
- Control modes: DMX-512, RDM (Remote Device Management)
- Pixel Control
- 0-100% dimming plus 16-bit fine dimming
- 6 dimmer curve modes
- Shutter control
- Strobe & pulse effects
- Gamma correction: 1.0, 2.0, 2.2, 2.4, 2.6 and 2.8
- With Wired Digital Communication Network

Pan/Tilt:

- Pan/Tilt: 540-degrees / 255-degrees
- 16-bit Fine Pan
- 16-bit Fine Tilt

Electrical:

- Multi-voltage operation: 100-240V, 50/60Hz

Dimensions & Weight:

- Dimensions (LxWxH): 8.5"x12"x18" / 215x302x457mm
- Weight: 35 lbs. / 16kg.

Rating / Approvals:

- cETLus Approved (Control #4000358)



DIMENSIONS (VERTICAL)

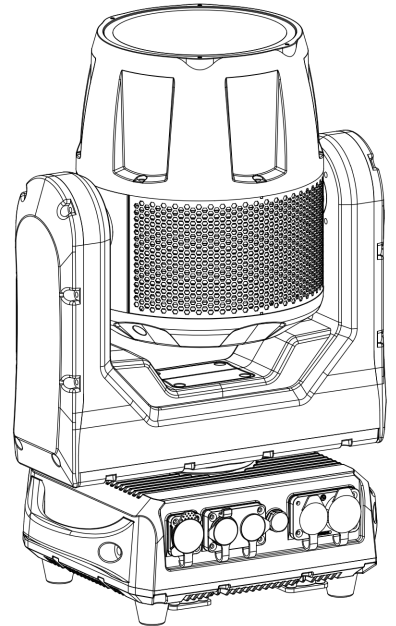
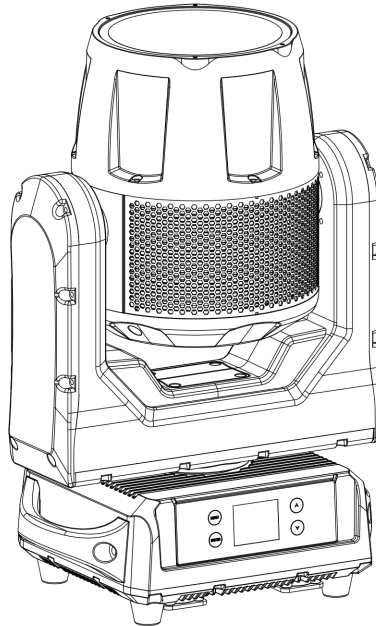
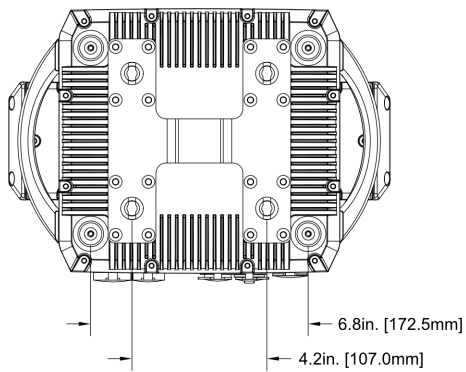
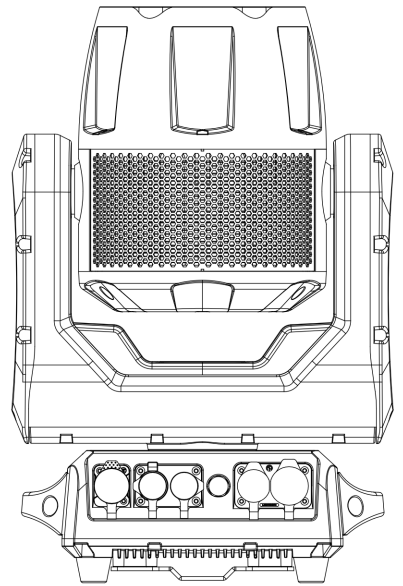
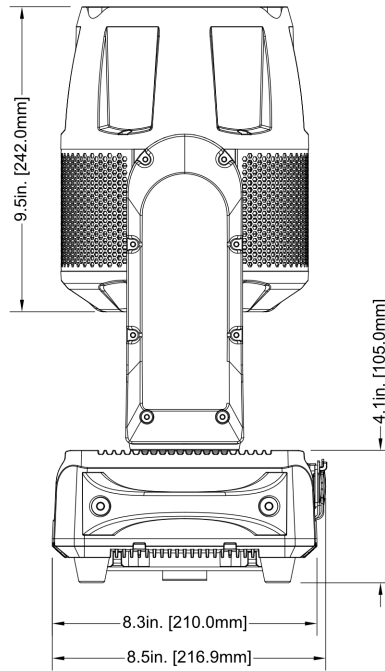
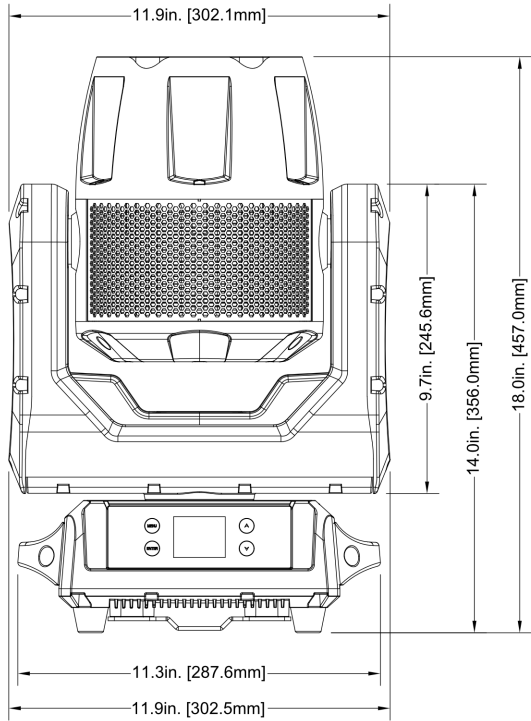
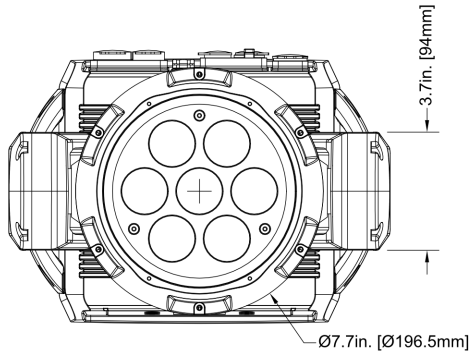

DIMENSIONS (HORIZONTAL)

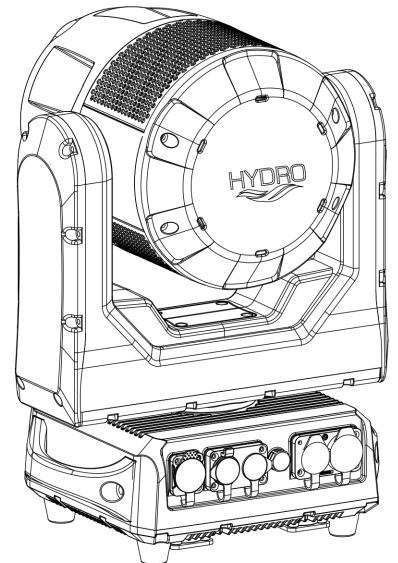
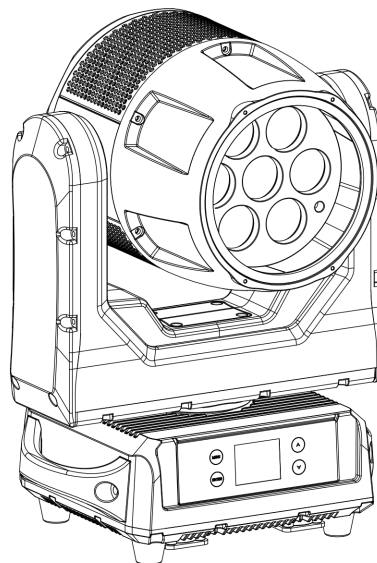
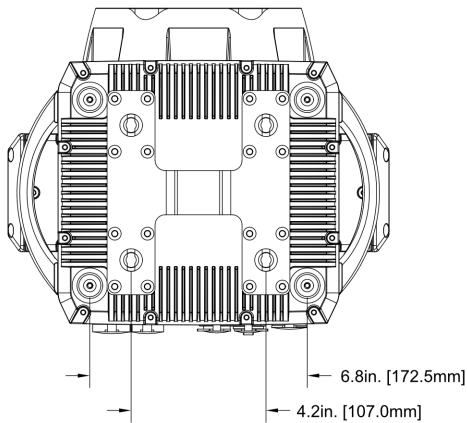
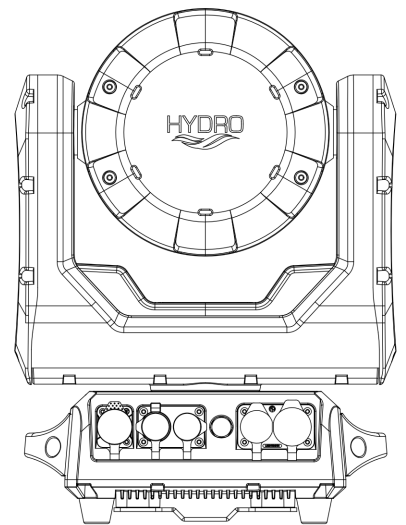
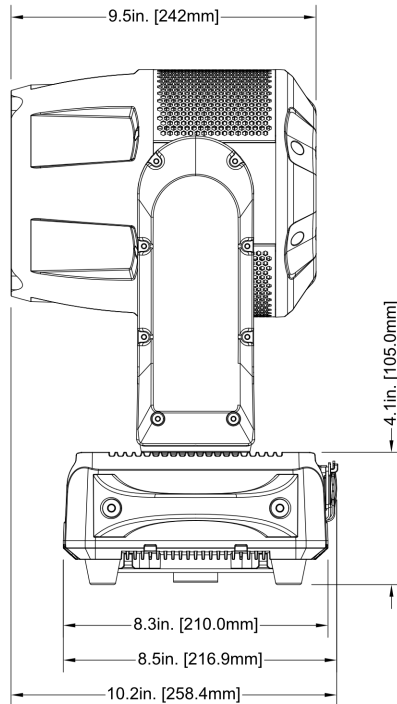
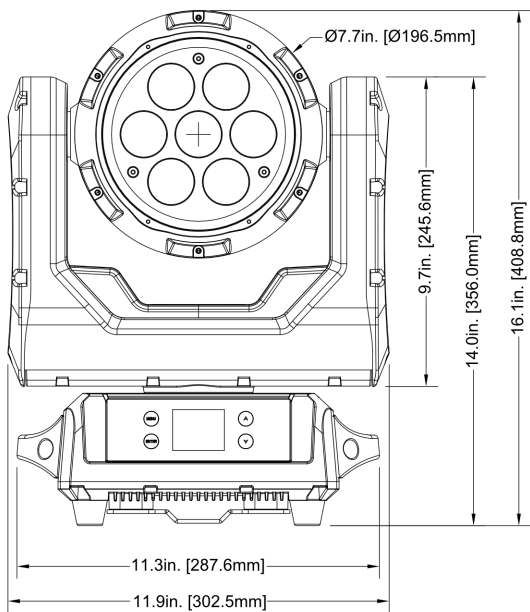
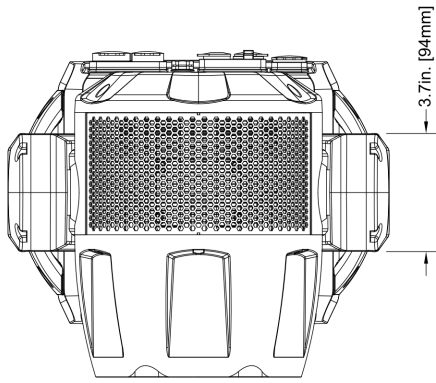

FCC STATEMENT

This device complies with Part 15 of the FCC Rules. Operation is subject to the following two conditions: (1) this device may not cause harmful interference, and (2) this device must accept any interference received, including interference that may cause undesired operation.

FCC RADIO FREQUENCY INTERFERENCE WARNINGS & INSTRUCTIONS

This product has been tested and found to comply with the limits as per Part 15 of the FCC Rules. These limits are designed to provide reasonable protection against harmful interference in a residential installation. This device uses and can radiate radio frequency energy and, if not installed and used in accordance with the included instructions, may cause harmful interference to radio communications. However, there is no guarantee that interference will not occur in a particular installation. If this device does cause harmful interference to radio or television reception, which can be determined by turning the device off and on, the user is encouraged to try to correct the interference by one or more of the following methods:

- Reorient or relocate the device.
- Increase the separation between the device and the receiver.
- Connect the device to an electrical outlet on a circuit different from which the radio receiver is connected.
- Consult the dealer or an experienced radio/TV technician for help.

Europe Energy Saving Notice

Energy Saving Matters (EuP 2009/125/EC)

Saving electric energy is a key to help protecting the environment. Please turn off all electrical products when they are not in use. To avoid power consumption in idle mode, disconnect all electrical equipment from power when not in use. Thank you



